

CP19038_ AMY-70-M-C2
 CP19108_ AMY-70-M-C2-WHT
 CP18873_ AMY-70-M-C2-PC
 CP19392_ AMY-70-M-C2-WHT-PC

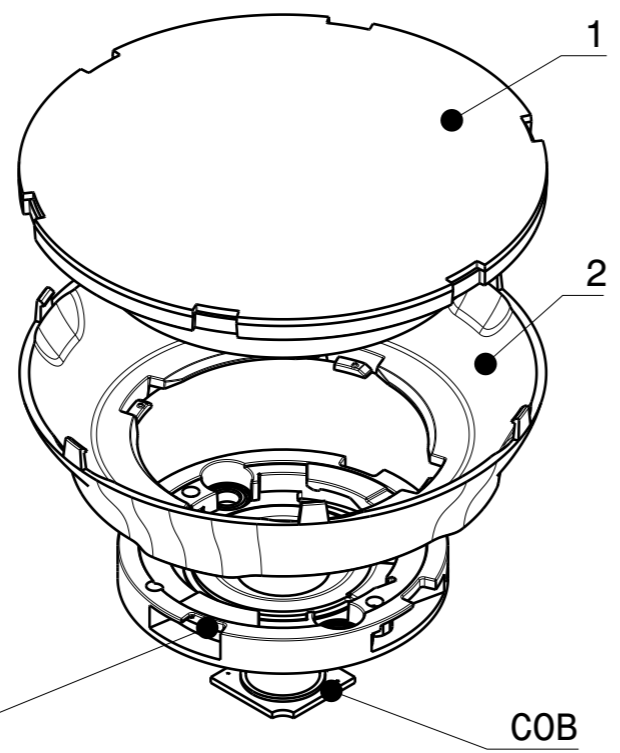
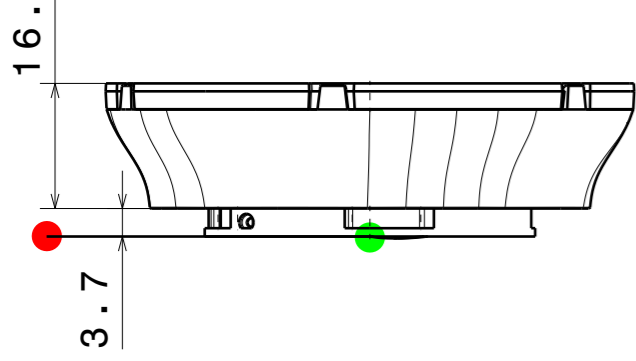

HEKLA
Connector

COB

CP19091_ AMY-70-M-B2
 CP19116_ AMY-70-M-B2-WHT
 CP18880_ AMY-70-M-B2-PC
 CP19399_ AMY-70-M-B2-WHT-PC

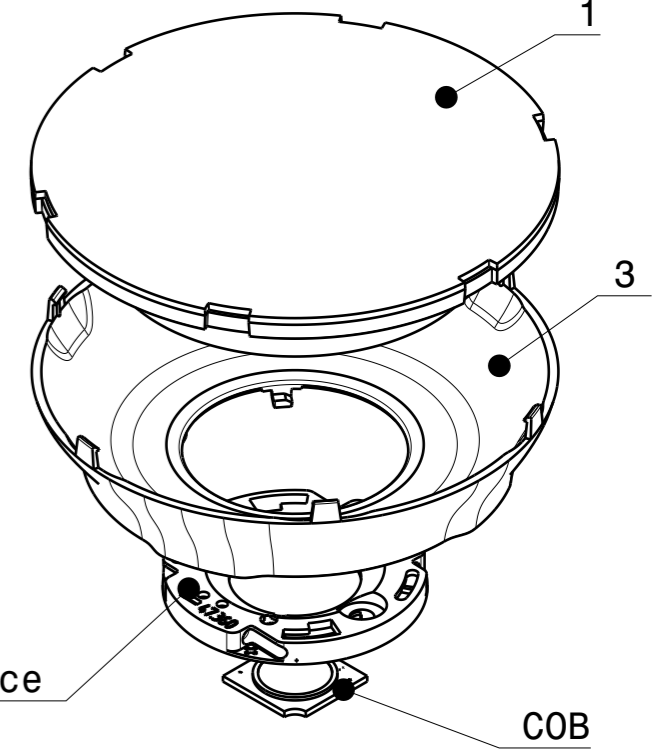
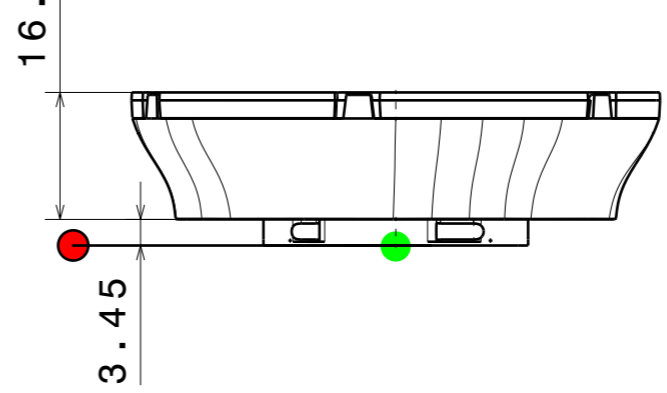

Connector
BJB / B+W 35mm-interface

COB

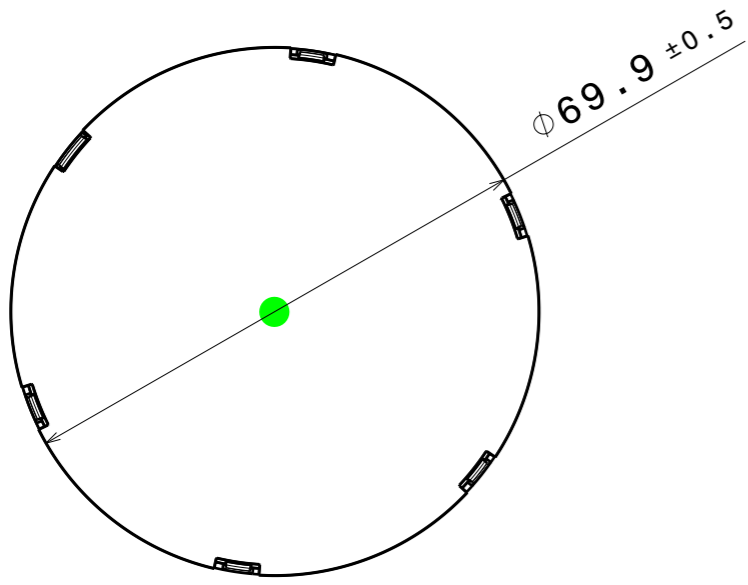

Top view
Scale: 1:1

INDEX	PART	TYPE	QTY	MATERIAL	COLOUR/COATING	ASSEMBLY CODES
1	AMY-70-M	LENS	1			
	C17777_ AMY-70-M			PMMA	CLEAR	
	C18866_ AMY-70-M-PC			PC	CLEAR	
2	HOLDER C	HOLDER	1			
	C19021_ AMY-70-HLD2-C			PC	BLACK	CP19038_ AMY-70-M-C2 CP18873_ AMY-70-M-C2-PC
	C19023_ AMY-70-HLD2-C-WHT			PC	WHITE	CP19108_ AMY-70-M-C2-WHT CP19392_ AMY-70-M-C2-WHT-PC
3	HOLDER B					
	C19022_ AMY-70-HLD2-B			PC	BLACK	CP19091_ AMY-70-M-B2 CP18880_ AMY-70-M-B2-PC
	C19024_ AMY-70-HLD2-B-WHT			PC	WHITE	CP19116_ AMY-70-M-B2-WHT CP19399_ AMY-70-M-B2-WHT-PC

MECHANICAL DRAWING		LEDiL
PRODUCT AMY-70-M		
Plastic moulding general tolerances according to DIN 16901-130 and applies if not otherwise shown in the drawing. Silicone moulding general tolerances according to ISO 3302-1 Class M3 and applies if not otherwise shown in the drawing.	FIRST ANGLE PROJECTION: 	This drawing is the property of LEDiL Oy. It may not be copied or otherwise distributed without prior written permission from LEDiL Oy.
SCALE 1:1	WEIGHT -	A3 SHEET 1/1

Notes

- PCB or heatsink level.
- LED location
- Ensure LED fitting from a product specific 3D model available from www.ledil.com
- For more details about installation please see LEDiL Installation Guide on www.ledil.com

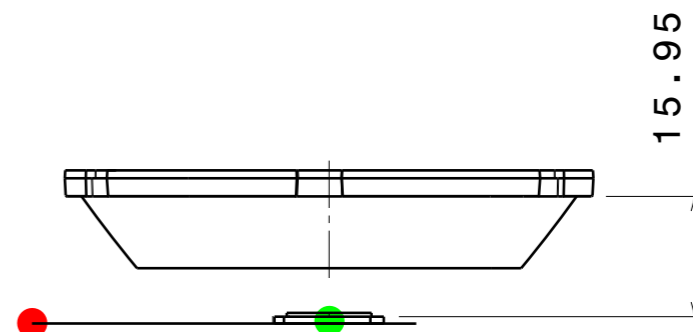
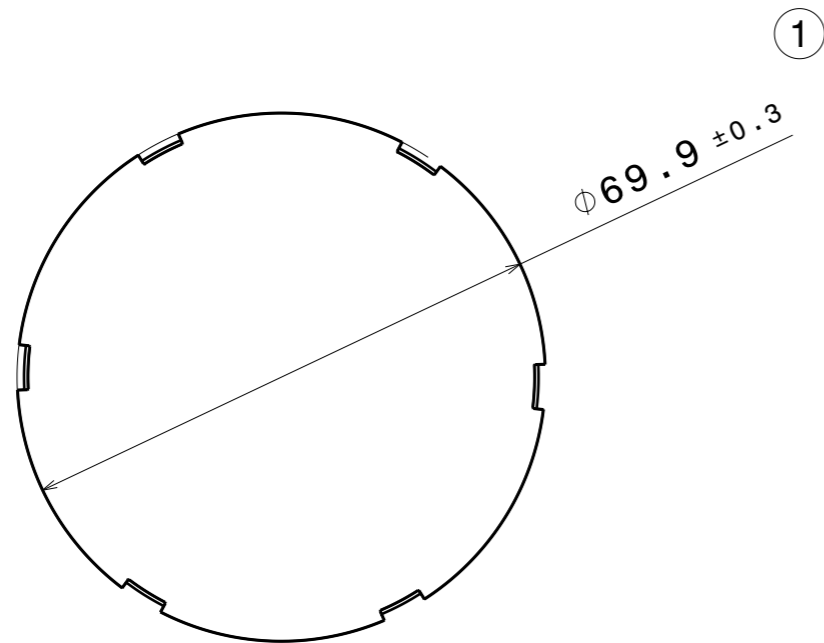
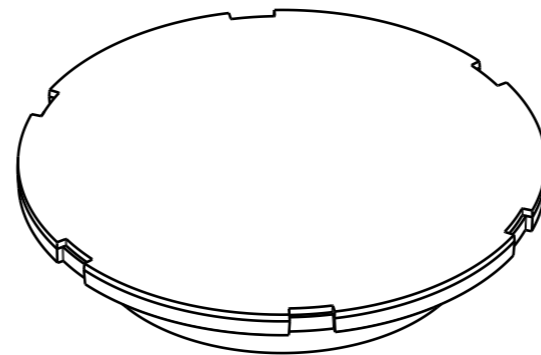
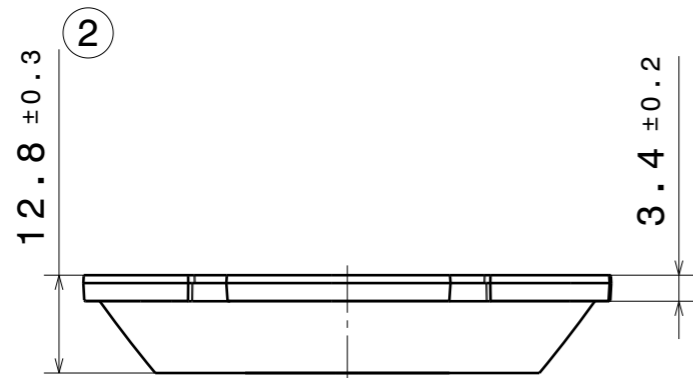

PART	TYPE	MATERIAL	COLOR / COATING
C17777_AMY-70-M	LENS	PMMA	CLEAR
C18866_AMY-70-M-PC	LENS	PC	CLEAR

MECHANICAL DRAWING

PRODUCT
AMY-70-M

Plastic moulding general tolerances according to DIN 16901-130 and applies if not otherwise shown in the drawing.
Silicone moulding general tolerances according to ISO 3302-1 Class M3 and applies if not otherwise shown in the drawing.

FIRST ANGLE PROJECTION:

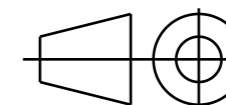

LEDiL

This drawing is the property of LEDiL Oy. It may not be copied or otherwise distributed without prior written permission from LEDiL Oy.

SCALE 1:1

WEIGHT -

A3 SHEET 1/1

Notes

	PCB or heatsink level.
	LED location
	Ensure LED fitting from a product specific 3D model available from www.ledil.com
	For more details about installation please see LEDiL Installation Guide on www.ledil.com