

CP19125_ AMY-50-W-C2
 CP19143_ AMY-50-W-C2-WHT
 CP18853_ AMY-50-W-C2-PC
 CP19377_ AMY-50-W-C2-WHT-PC

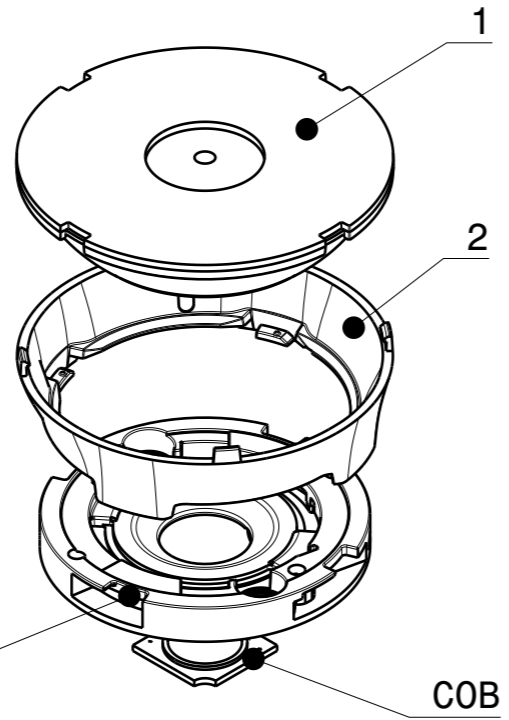

CP19134_ AMY-50-W-B2
 CP19152_ AMY-50-W-B2-WHT
 CP18860_ AMY-50-W-B2-PC
 CP19385_ AMY-50-W-B2-WHT-PC

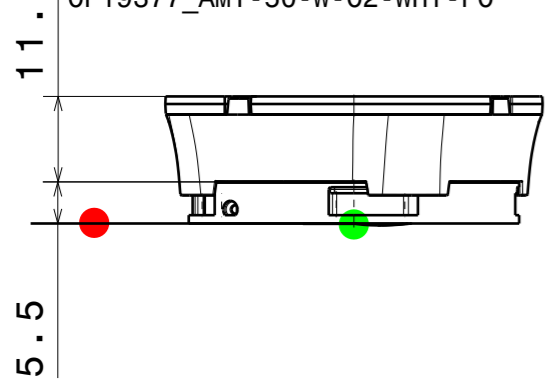
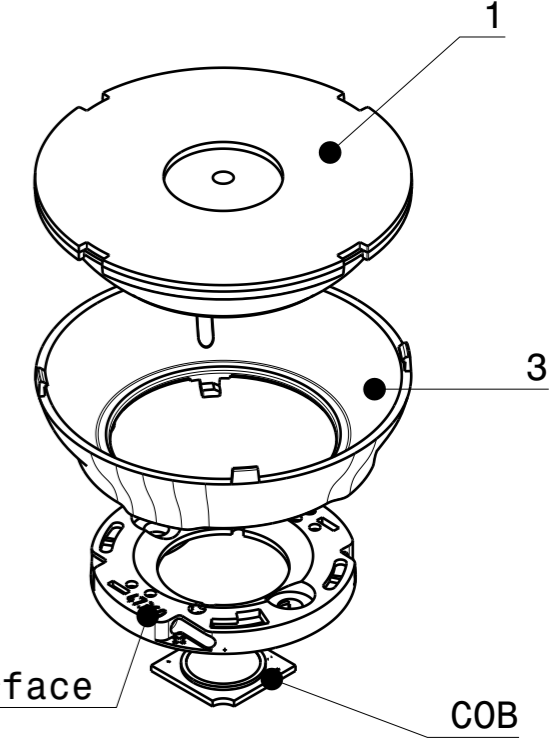
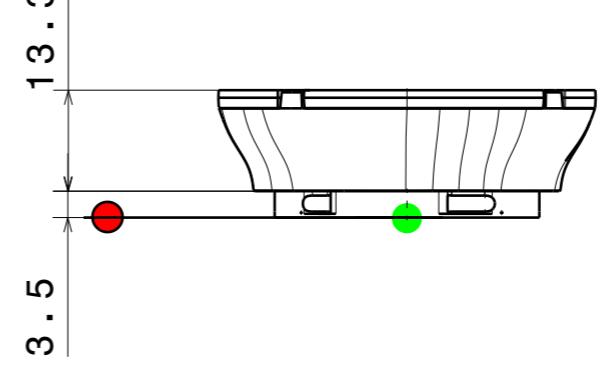

HEKLA
Connector

Connector
BJB / B+W 35mm-interface

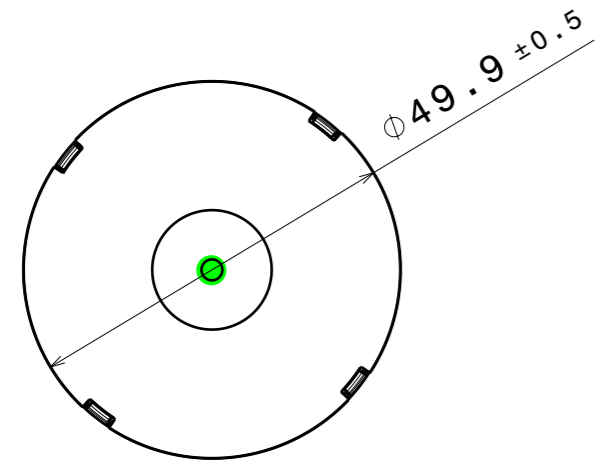

Top view
Scale: 1:1

INDEX	PART	TYPE	QTY	MATERIAL	COLOUR/COATING	ASSEMBLY CODES
1	AMY-50-W	LENS	1			
	C17688_ AMY-50-W			PMMA	CLEAR	
	C18846_ AMY-50-W-PC			PC	CLEAR	
2	HOLDER C	HOLDER	1			
	C19017_ AMY-50-HLD2-C			PC	BLACK	CP19125_ AMY-50-W-C2 CP18853_ AMY-50-W-C2-PC
	C19019_ AMY-50-HLD2-C-WHT			PC	WHITE	CP19143_ AMY-50-W-C2-WHT CP19377_ AMY-50-W-C2-WHT-PC
3	HOLDER B					
	C19018_ AMY-50-HLD2-B			PC	BLACK	CP19134_ AMY-50-W-B2 CP18860_ AMY-50-W-B2-PC
	C19020_ AMY-50-HLD2-B-WHT			PC	WHITE	CP19152_ AMY-50-W-B2-WHT CP19385_ AMY-50-W-B2-WHT-PC

MECHANICAL DRAWING		LEDiL
PRODUCT AMY-50-W		
Plastic moulding general tolerances according to DIN 16901-130 and applies if not otherwise shown in the drawing. Silicone moulding general tolerances according to ISO 3302-1 Class M3 and applies if not otherwise shown in the drawing.	FIRST ANGLE PROJECTION: 	This drawing is the property of LEDiL Oy. It may not be copied or otherwise distributed without prior written permission from LEDiL Oy.
SCALE 1:1	WEIGHT -	A3 SHEET 1/1

Notes

- PCB or heatsink level.
- LED location
- Ensure LED fitting from a product specific 3D model available from www.ledil.com
- For more details about installation please see LEDiL Installation Guide on www.ledil.com

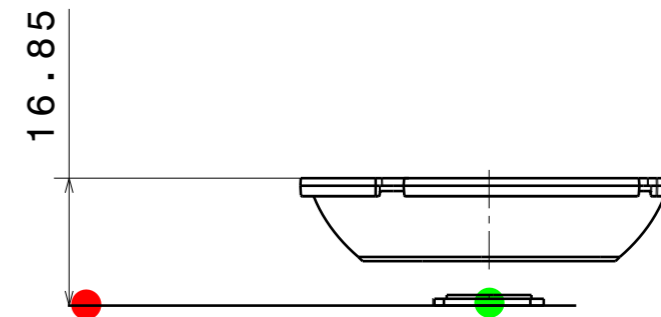
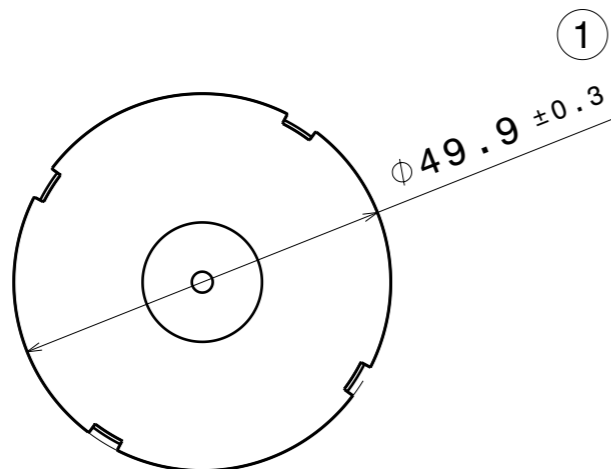
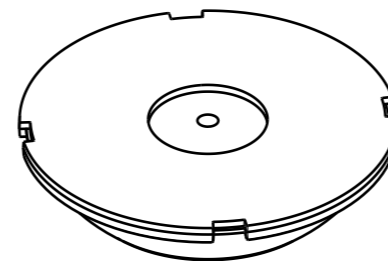
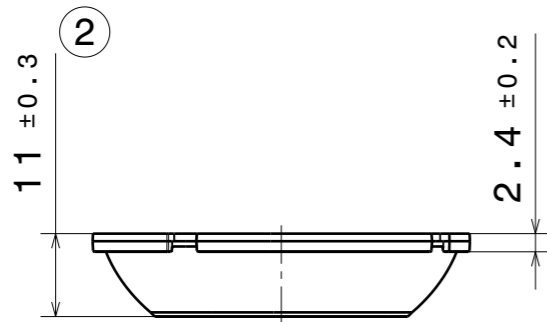

PART	TYPE	MATERIAL	COLOR / COATING
C17688_AMY-50-W	LENS	PMMA	CLEAR
C18846_AMY-50-W-PC	LENS	PC	CLEAR

MECHANICAL DRAWING

PRODUCT
AMY-50-W

LEDiL

Plastic moulding general tolerances according to DIN 16901-130 and applies if not otherwise shown in the drawing. Silicone moulding general tolerances according to ISO 3302-1 Class M3 and applies if not otherwise shown in the drawing.

FIRST ANGLE PROJECTION:

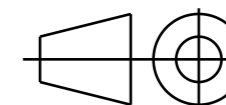

This drawing is the property of LEDiL Oy. It may not be copied or otherwise distributed without prior written permission from LEDiL Oy.

SCALE 1:1

WEIGHT -

A3 SHEET 1/1

Notes

●	PCB or heatsink level.
●	LED location
	Ensure LED fitting from a product specific 3D model available from www.ledil.com
	For more details about installation please see LEDiL Installation Guide on www.ledil.com