

CP19627\_ AMY-45-ZOOM-B  
CP19632\_ AMY-45-ZOOM-B-WHT

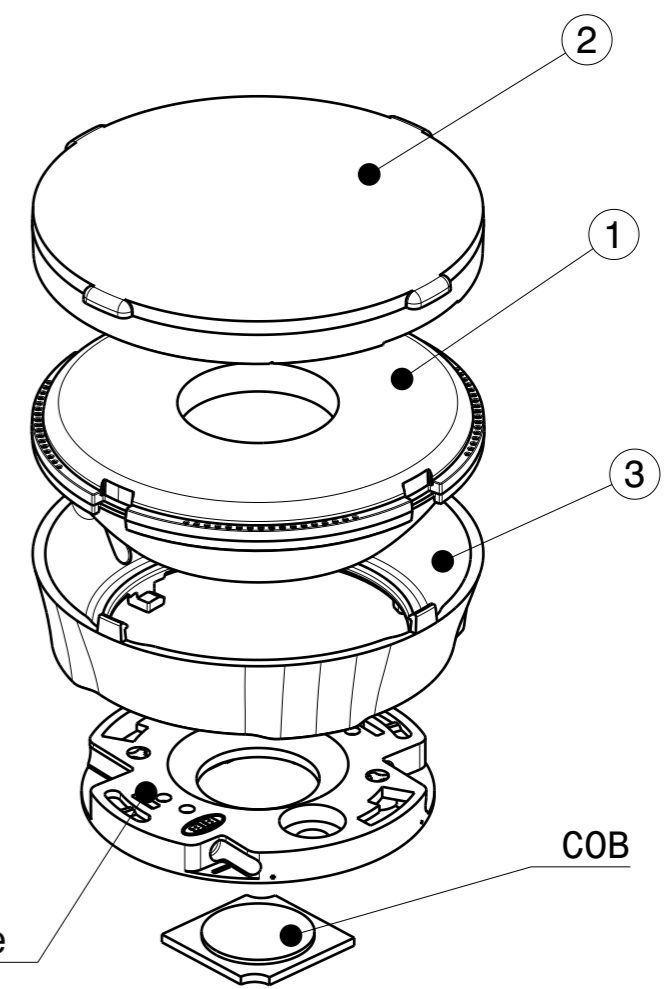
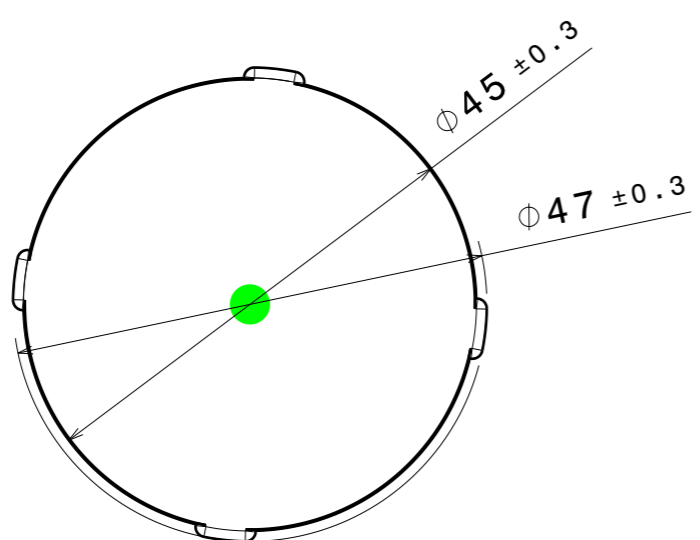

Connector  
LEDiL SOCKET-B-35 or  
BJB / B+W 35mm-interface

INDEX	PART	TYPE	QTY	MATERIAL	COLOUR / COATING	ASSEMBLY CODES
1	C18532_ AMY-45-ZOOM	LENS	1	PMMA	Clear	
2	C18533_ AMY-45-ZOOM-SUB	SUBLENS	1	PMMA	Clear	
3	HOLDER B	HOLDER	1			
	C19577_ AMY-45-HLD2-B			PC	Black	CP19627_ AMY-45-ZOOM-B
	C19578_ AMY-45-HLD2-B-WHT			PC	White	CP19632_ AMY-45-ZOOM-B-WHT

<b>MECHANICAL DRAWING</b>		<b>LEDiL</b>
PRODUCT <b>AMY-45-ZOOM</b>		
Plastic moulding general tolerances according to DIN 16901-130 and applies if not otherwise shown in the drawing. Silicone moulding general tolerances according to ISO 3302-1 Class M3 and applies if not otherwise shown in the drawing.	FIRST ANGLE PROJECTION: 	This drawing is the property of LEDiL Oy. It may not be copied or otherwise distributed without prior written permission from LEDiL Oy.
SCALE 4:3	WEIGHT -	A3 SHEET 1/4

**Notes**

	PCB or heatsink level.
	LED location
	Ensure LED fitting from a product specific 3D model available from <a href="http://www.ledil.com">www.ledil.com</a>
	For more details about installation please see LEDiL Installation Guide on <a href="http://www.ledil.com">www.ledil.com</a>

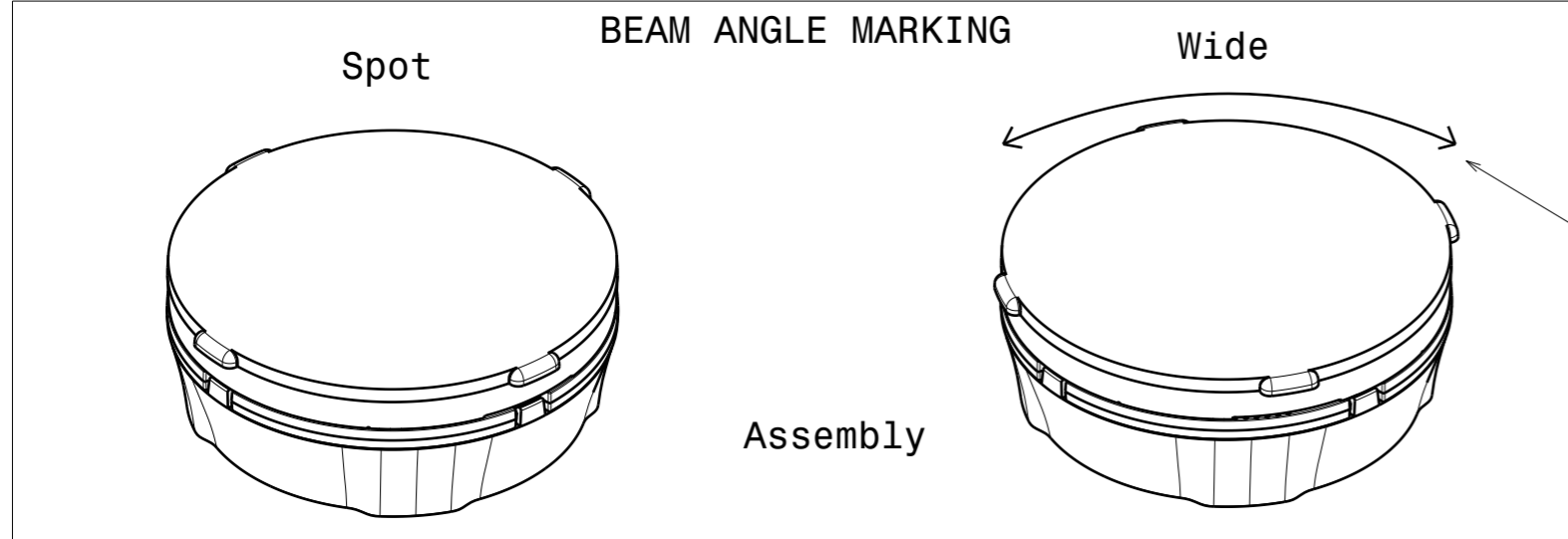

SUB-lens rotate freely.  
Beam angle changing smoothly.  
spot - wide - spot - wide ...

22.5 degrees rotation angle between spot and wide

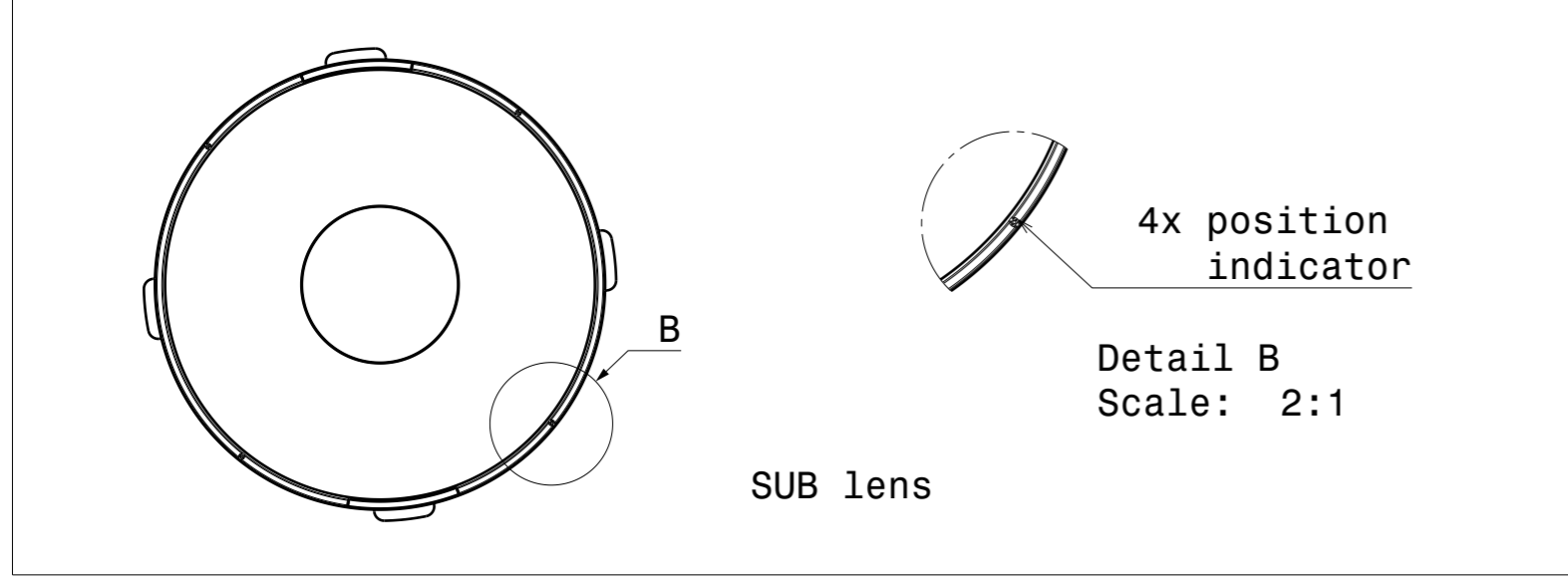
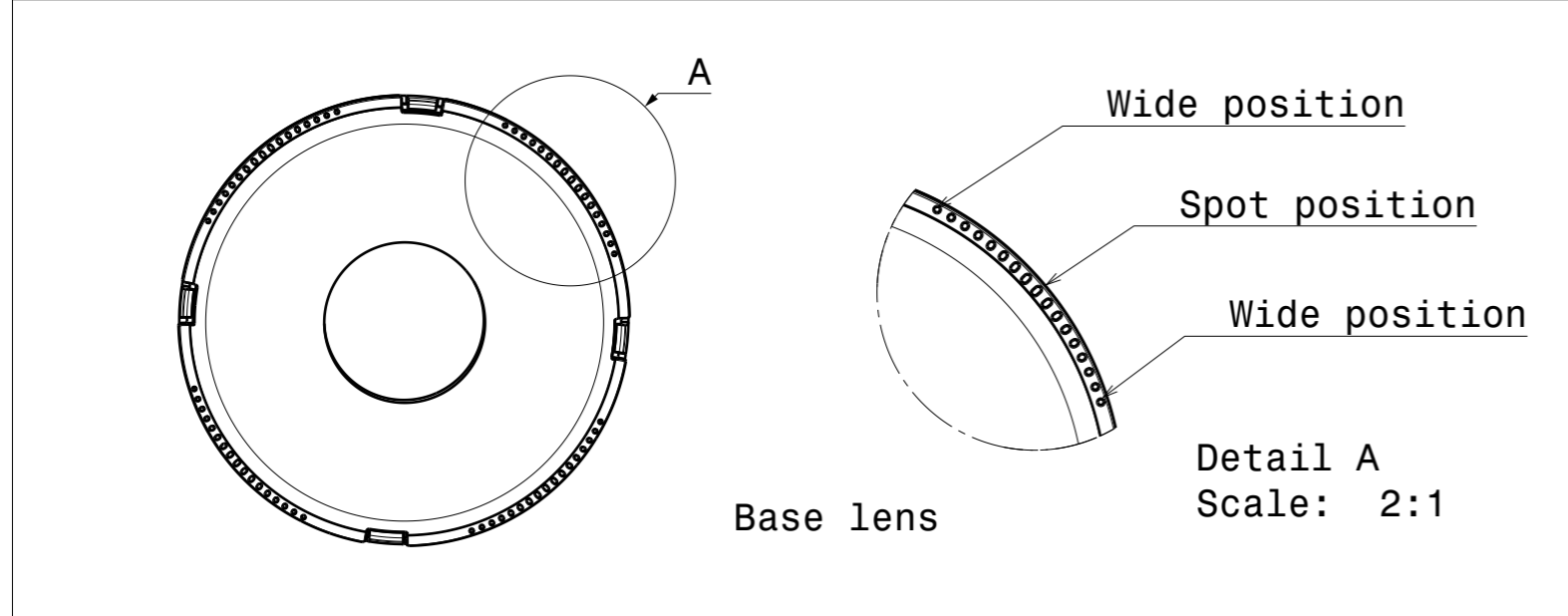

**MECHANICAL DRAWING**

PRODUCT **AMY-45-ZOOM**

**LEDiL**

Plastic moulding general tolerances according to DIN 16901-130 and applies if not otherwise shown in the drawing.  
Silicone moulding general tolerances according to ISO 3302-1 Class M3 and applies if not otherwise shown in the drawing.

FIRST ANGLE PROJECTION:

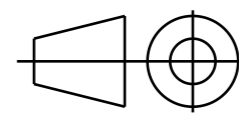

This drawing is the property of LEDiL Oy. It may not be copied or otherwise distributed without prior written permission from LEDiL Oy.

SCALE 4:3

WEIGHT -

A3 SHEET 2/4

**Notes**

	PCB or heatsink level.
	LED location
	Ensure LED fitting from a product specific 3D model available from <a href="http://www.ledil.com">www.ledil.com</a>
	For more details about installation please see LEDiL Installation Guide on <a href="http://www.ledil.com">www.ledil.com</a>

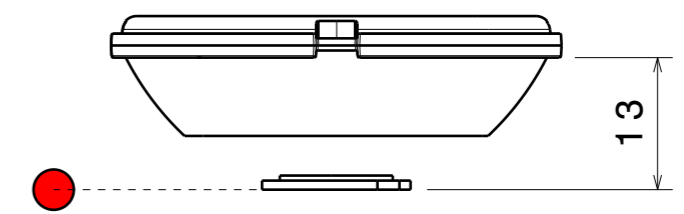
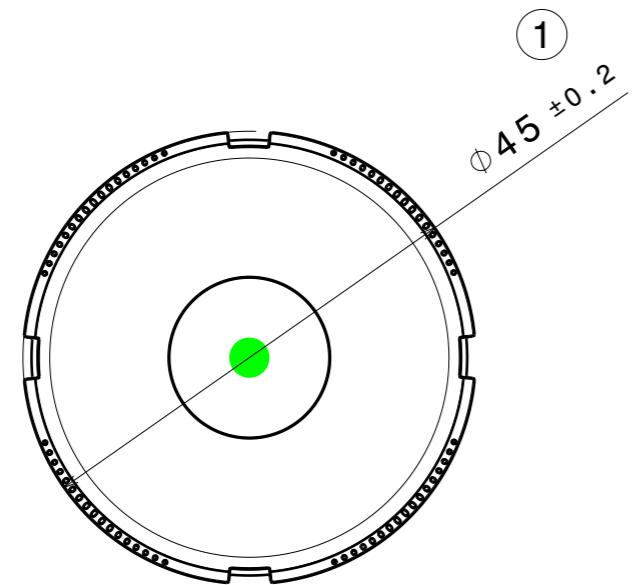
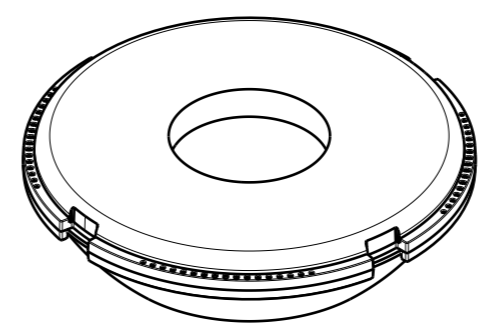
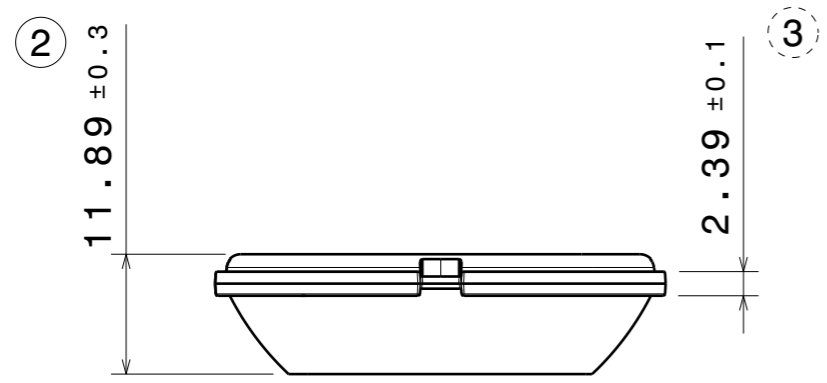

PART	TYPE	MATERIAL	COLOUR / COATING
C18532_ AMY-45-ZOOM	LENS	PMMA	Clear

**MECHANICAL DRAWING**

PRODUCT  
**AMY-45-ZOOM**

**LEDiL**

Plastic moulding general tolerances according to DIN 16901-130 and applies if not otherwise shown in the drawing. Silicone moulding general tolerances according to ISO 3302-1 Class M3 and applies if not otherwise shown in the drawing.

FIRST ANGLE PROJECTION:

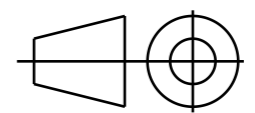

This drawing is the property of LEDiL Oy. It may not be copied or otherwise distributed without prior written permission from LEDiL Oy.

SCALE 4:3

WEIGHT -

A3 SHEET 3/4

**Notes**

	PCB or heatsink level.
	LED location
	Ensure LED fitting from a product specific 3D model available from <a href="http://www.ledil.com">www.ledil.com</a>
	For more details about installation please see LEDiL Installation Guide on <a href="http://www.ledil.com">www.ledil.com</a>

4

4

3

3

2

2

1

1

H

G

B

A

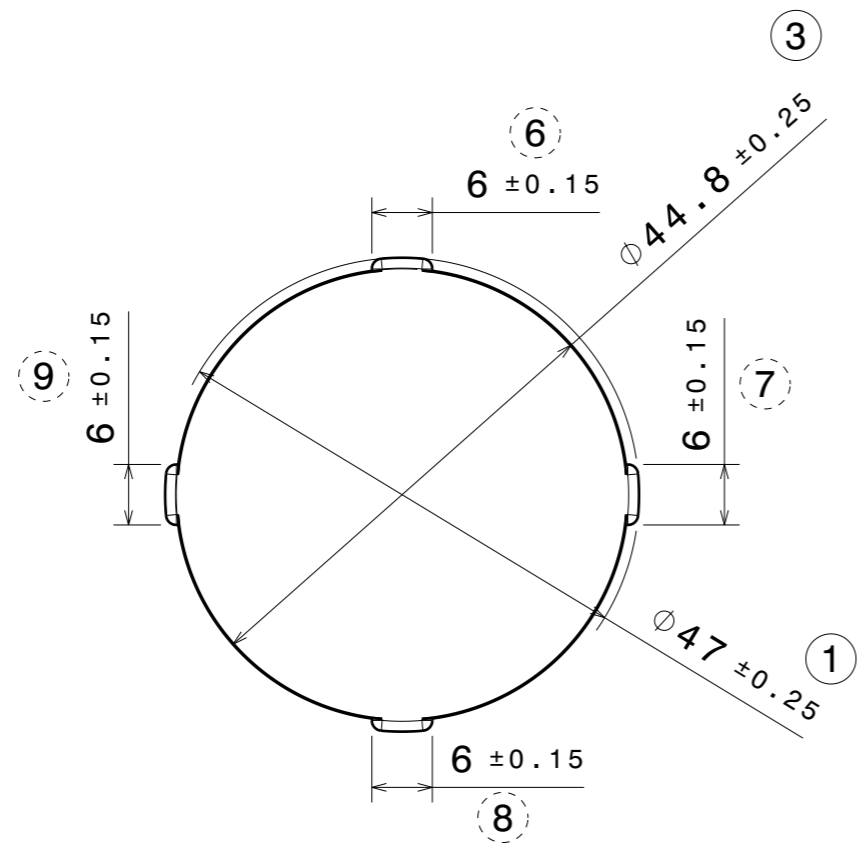
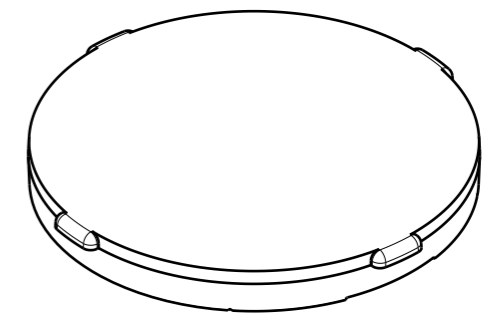
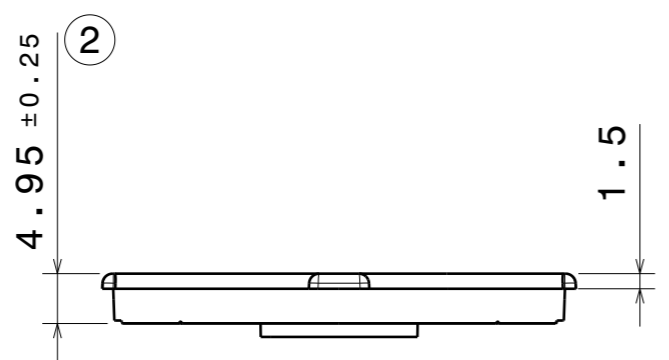

PART	TYPE	MATERIAL	COLOUR / COATING
C18533_AMY-45-ZOOM-SUB	SUBLENS	PMMA	Clear

**MECHANICAL DRAWING**

PRODUCT  
**AMY-45-ZOOM**

**LEDiL**

Plastic moulding general tolerances according to DIN 16901-130 and applies if not otherwise shown in the drawing. Silicone moulding general tolerances according to ISO 3302-1 Class M3 and applies if not otherwise shown in the drawing.

FIRST ANGLE PROJECTION:

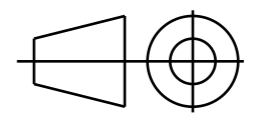

This drawing is the property of LEDiL Oy. It may not be copied or otherwise distributed without prior written permission from LEDiL Oy.

SCALE 4:3

WEIGHT -

A3 SHEET 4/4

**Notes**

- PCB or heatsink level.
- LED location
- Ensure LED fitting from a product specific 3D model available from [www.ledil.com](http://www.ledil.com)
- For more details about installation please see LEDiL Installation Guide on [www.ledil.com](http://www.ledil.com)