

Scale: 1:1

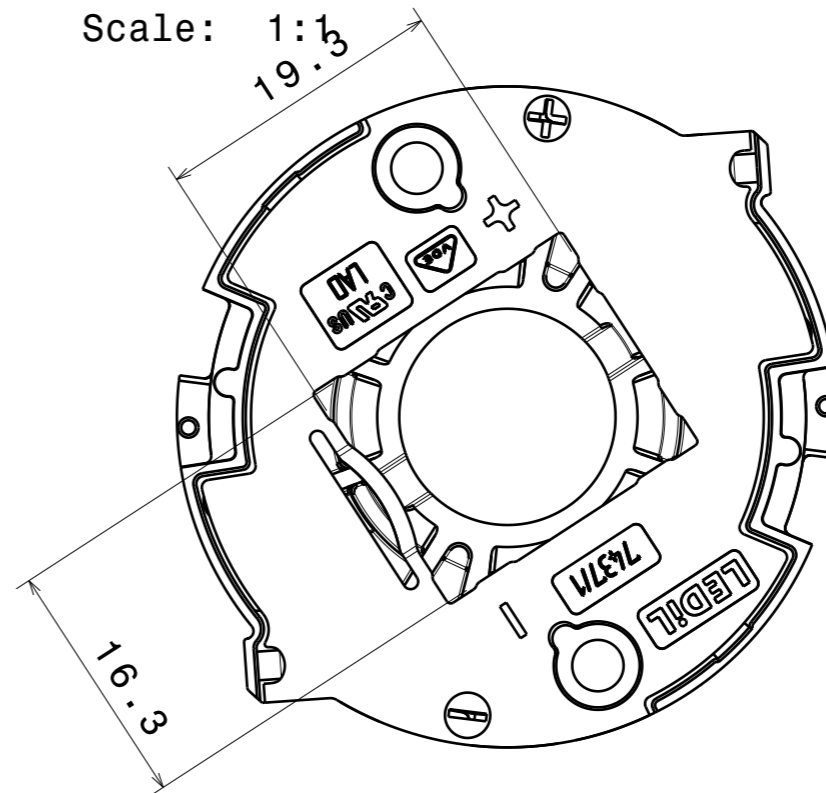

PART	TYPE	MATERIAL	COLOR / COATING	COB size (mm)	LES (up to)
F17437_HEKLA-H-G2	Socket	PBT	White	19x16	14 mm

**MECHANICAL DRAWING**

PRODUCT  
**HEKLA-G2**

Plastic moulding general tolerances according to DIN 16901-130 and applies if not otherwise shown in the drawing.  
Silicone moulding general tolerances according to ISO 3302-1 Class M3 and applies if not otherwise shown in the drawing.

FIRST ANGLE PROJECTION:

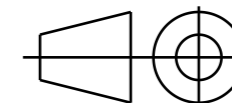

SCALE 2:1 (1:1)

WEIGHT 5,8 g

**LEDiL®**

This drawing is the property of LEDiL Oy. It may not be copied or otherwise distributed without prior written permission from LEDiL Oy.

A3 SHEET 1/1

**Notes**

- PCB or heatsink level.
- LED location
- Ensure LED fitting from a product specific 3D model available from [www.ledil.com](http://www.ledil.com)
- For more details about installation please see LEDiL Installation Guide on [www.ledil.com](http://www.ledil.com)

GENERAL INFORMATION	
RATED VOLTAGE/CURRENT	150VDC/3A
ELECTRICAL REQUIREMENTS	IEC 60838-2-2
WIRES	AWG 20-22 (0,35-0,5 mm <sup>2</sup> ) (Solid and Tinned)
WIRE STRIP LENGTH	8 +1 mm
FASTENING	SCREWS 2XM3, WASHER 2XM3, Screw hole distance 35mm
MAX.SCREW FIXING TORQUE	0,5Nm
MAX.TIM THICKNESS	0,25mm
RATED TEMPERATURE	110°C

**GENERAL ASSEMBLY INSTRUCTION**

AWG 20-22  
Strip length 8mm

Screws M3+Washers  
(DIN125/DIN127)  
Max.torque 0,5Nm

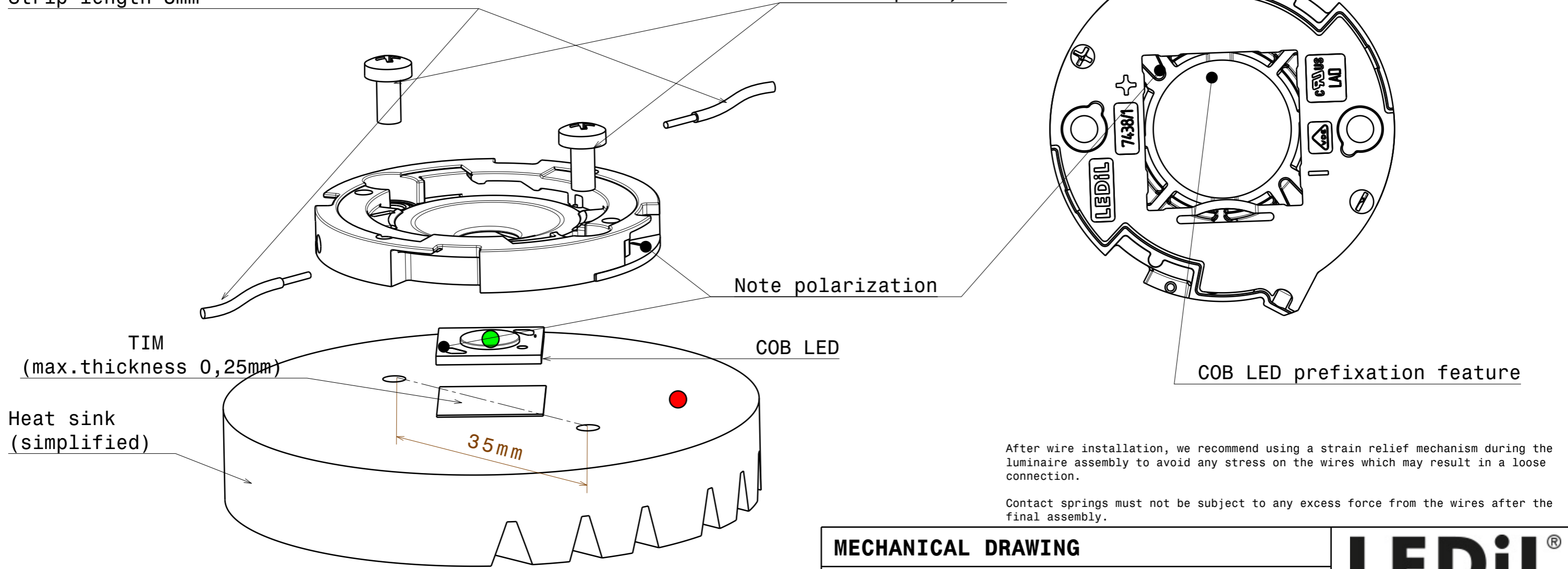

After wire installation, we recommend using a strain relief mechanism during the luminaire assembly to avoid any stress on the wires which may result in a loose connection.  
Contact springs must not be subject to any excess force from the wires after the final assembly.

**Notes**

- PCB or Heat Sink level
- Led location
- Ensure LED fitting, see our web site and/or 3D model for part detail.

<b>MECHANICAL DRAWING</b>		<b>LEDiL<sup>®</sup></b>
PRODUCT HEKLA-G2		
Tolerances if not otherwise shown According to DIN 16901-130	FIRST ANGLE PROJECTION: 	This drawing is the property of LEDiL Oy. It may not be reproduced, copied or communicated without a written agreement with LEDiL Oy.
SCALE 2:1	SIZE A3	SHEET 2/2