

AMY/YASMEEN 50/70-OVAL/WAS DIRECTION

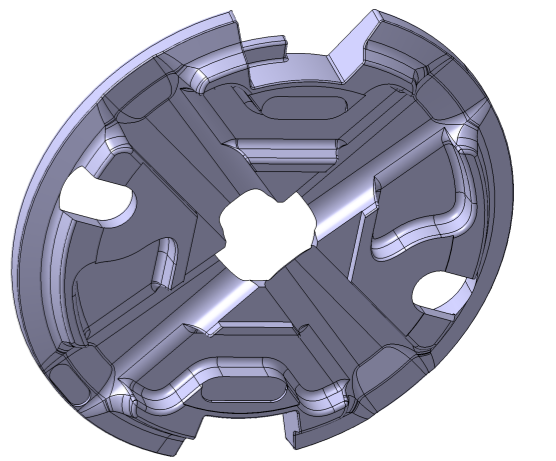

AMY/YASMEEN 35-OVAL/WAS DIRECTION

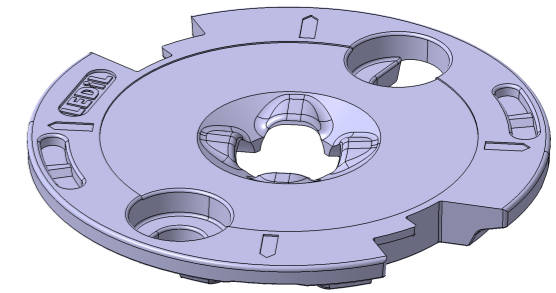
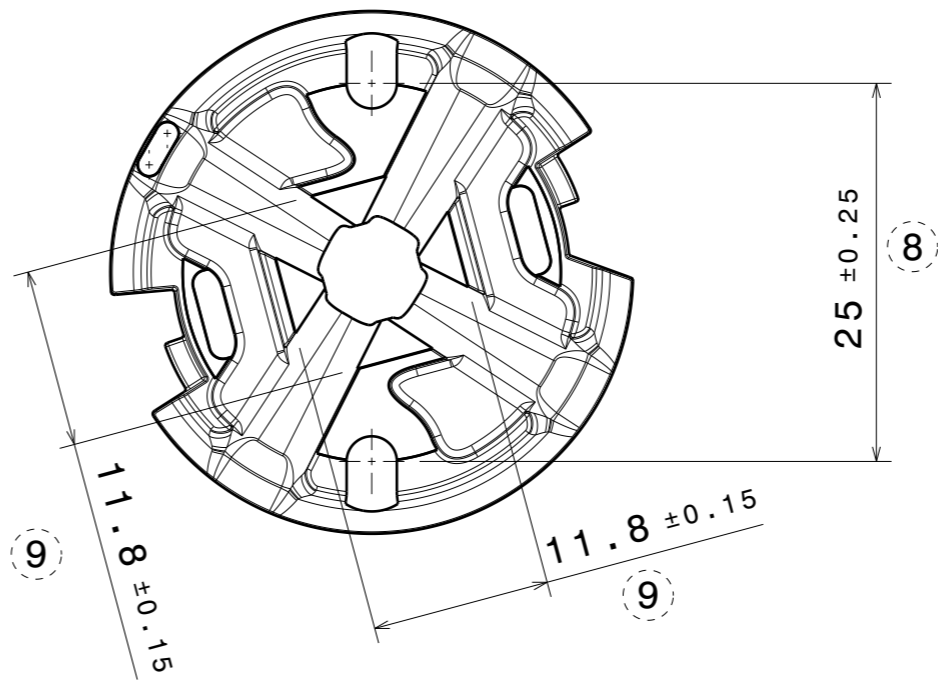
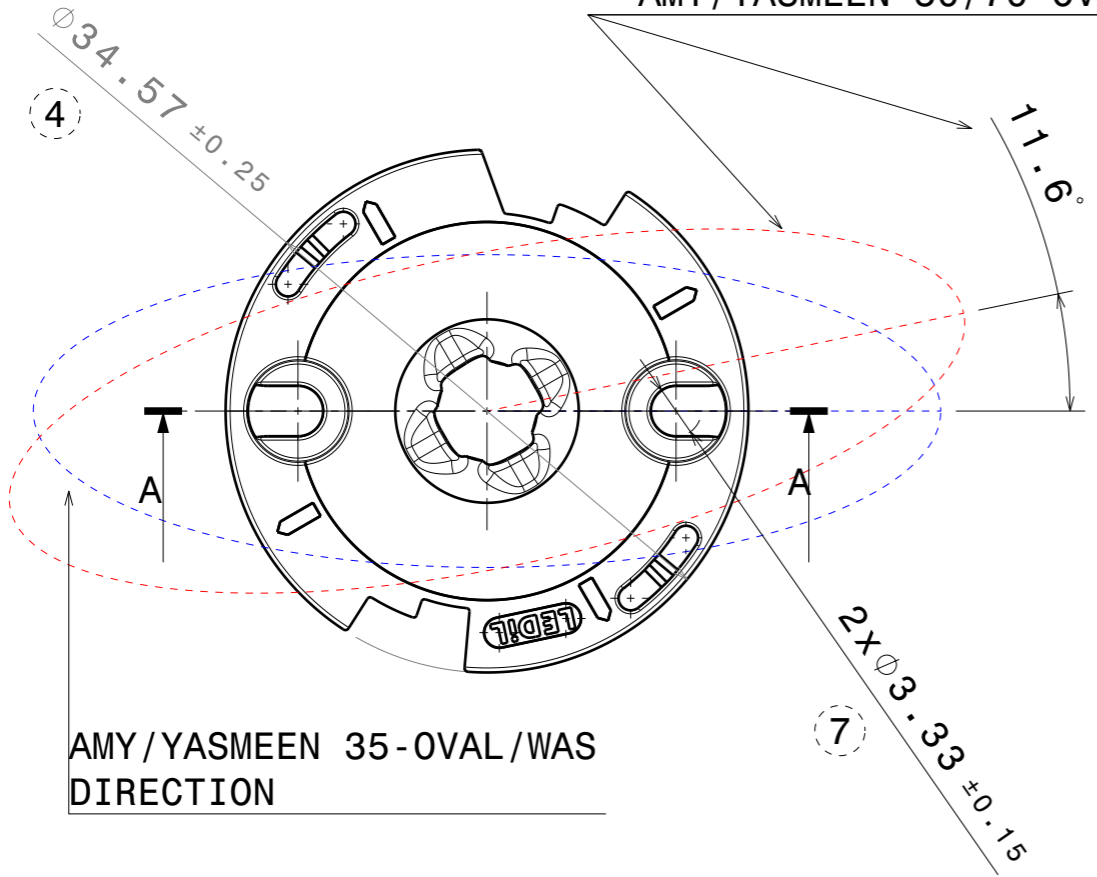
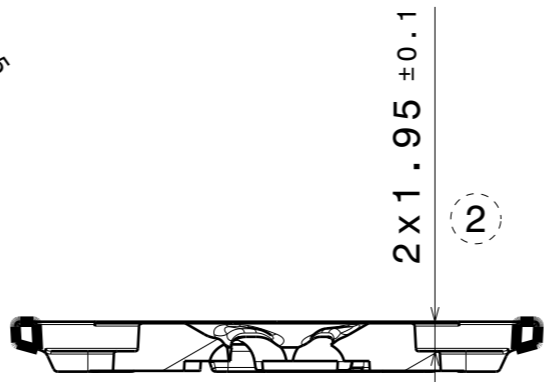
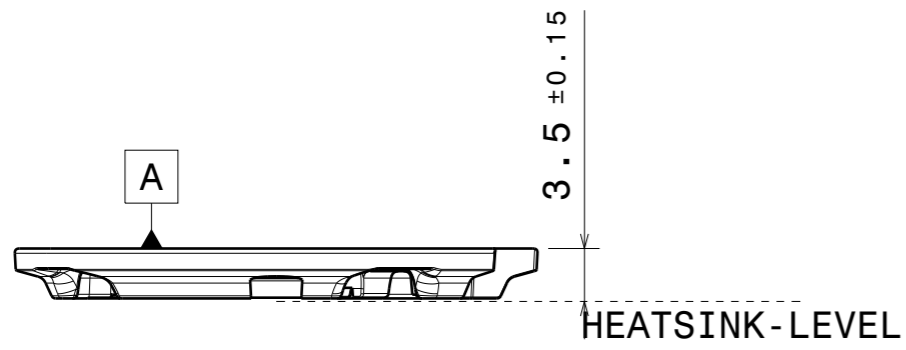

Section view A-A
Scale: 2:1

- Screw fastening moment recommendation: 0,5Nm
- Notice OVAL / WAS directions for 35 / 50 / 70 versions.
- Soldering height max 1,4 mm

PART	TYPE	MATERIAL	COLOR / COATING
C19424_SOCKET-B-35-M	SOCKET	Crastin FR684NH1	white

MECHANICAL DRAWING	
PRODUCT HEKLA	
Plastic moulding general tolerances according to DIN 16901-130 and applies if not otherwise shown in the drawing. Silicone moulding general tolerances according to ISO 3302-1 Class M3 and applies if not otherwise shown in the drawing.	FIRST ANGLE PROJECTION:
SCALE 1:1	WEIGHT 2g

LEDiL

This drawing is the property of LEDiL Oy. It may not be copied or otherwise distributed without prior written permission from LEDiL Oy.

A3 SHEET 1/1

Notes

	PCB or heatsink level.
	LED location
	Ensure LED fitting from a product specific 3D model available from www.ledil.com
	For more details about installation please see LEDiL Installation Guide on www.ledil.com