

C18083_LEILA-Y-SS

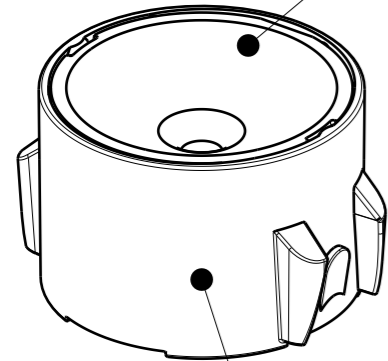

C19437_LEILA-Y-SC2-HLD

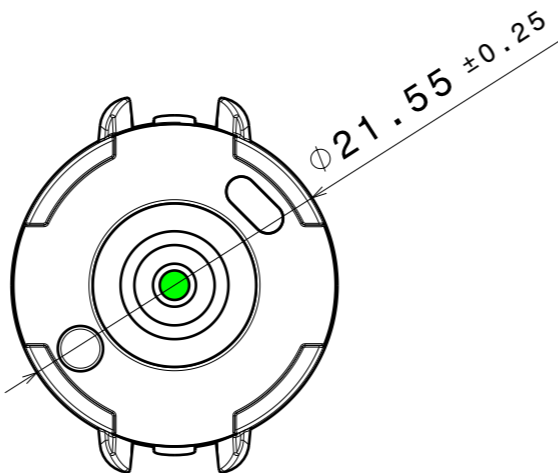

Recommended PAD design

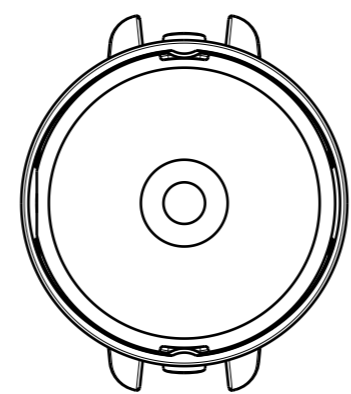
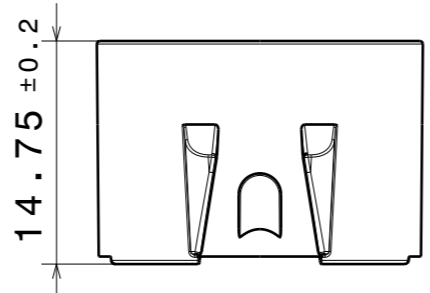
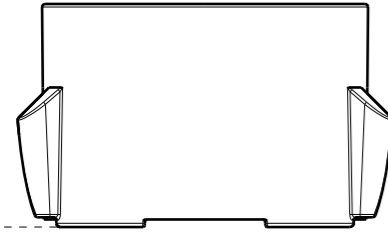
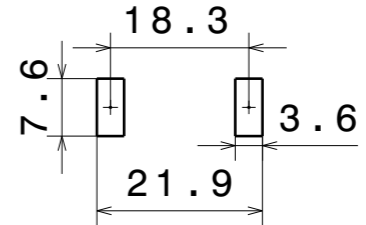

CP19439_LEILA-Y-SC2-SS

COMPONENTS

PART	TYPE	COUNT	MATERIAL	COLOR / COATING
C18083_LEILA-Y-SS	LENS	1	PMMA	CLEAR
C19437_LEILA-Y-SC2-HLD	HOLDER	1	PC	BLACK

MECHANICAL DRAWING		LEDiL
PRODUCT LEILA-Y-SC2-SS		
Plastic moulding general tolerances according to DIN 16901-130 and applies if not otherwise shown in the drawing. Silicone moulding general tolerances according to ISO 3302-1 Class M3 and applies if not otherwise shown in the drawing.	FIRST ANGLE PROJECTION: 	This drawing is the property of LEDiL Oy. It may not be copied or otherwise distributed without prior written permission from LEDiL Oy.
SCALE 2:1	WEIGHT -	A3 SHEET 1/1

Notes

	PCB or heatsink level.
	LED location
	Ensure LED fitting from a product specific 3D model available from www.ledil.com
	For more details about installation please see LEDiL Installation Guide on www.ledil.com