

DATE
17.02.2020

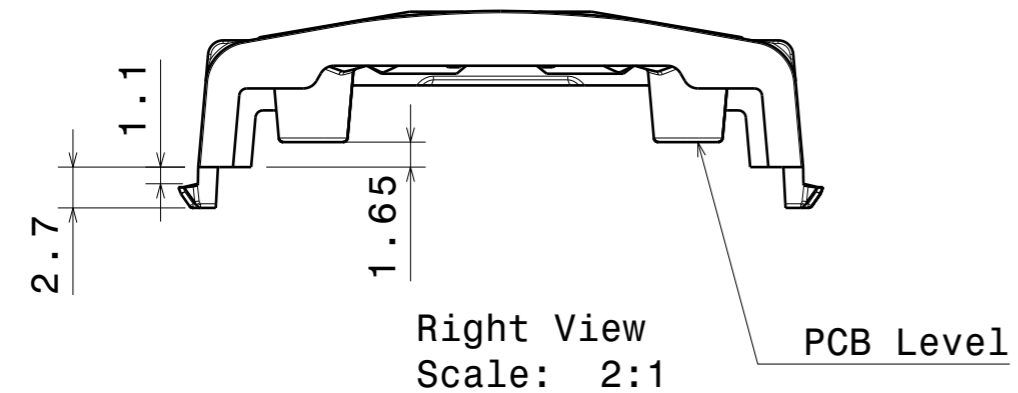
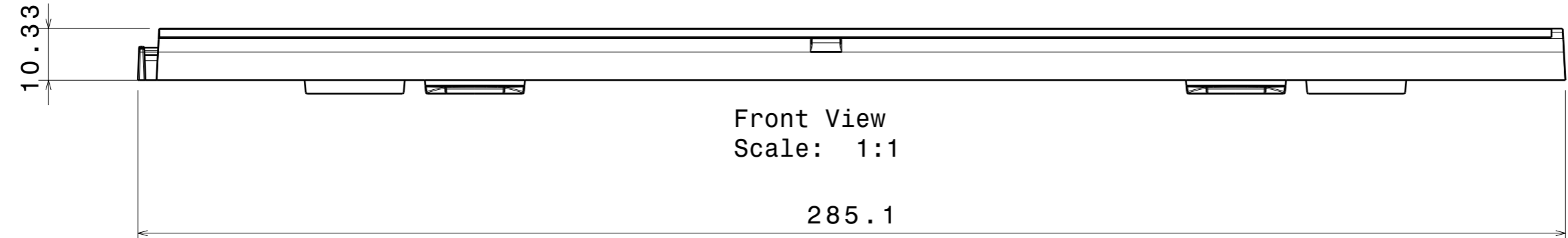
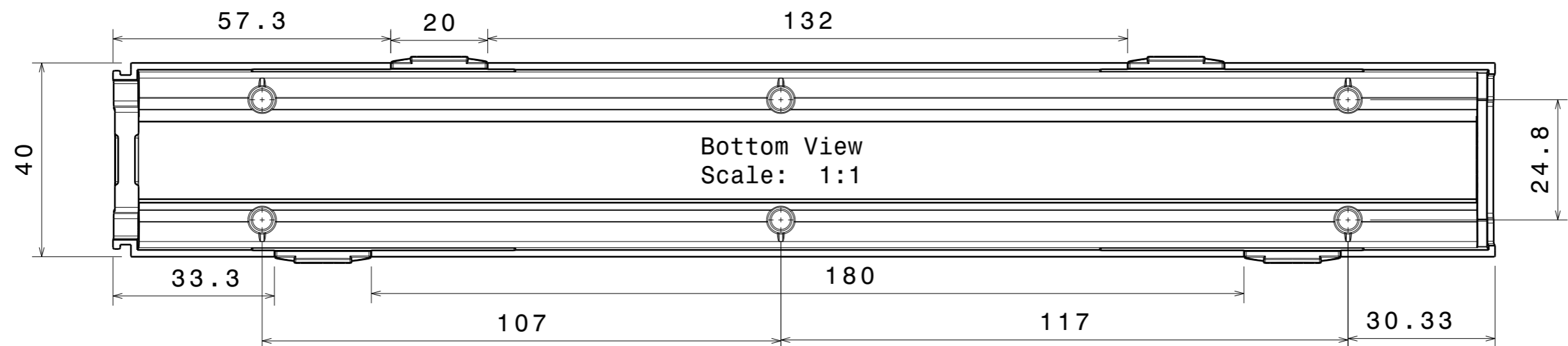

Notes

- PCB or heatsink level.
- LED location
- Ensure LED fitting from a product specific 3D model available from www.ledil.com
- For more details about installation please see LEDiL Installation Guide on www.ledil.com

PART	TYPE	MATERIAL	COLOR / COATING
F16048_LINNEA-UP		PC Lexan 123R	CLEAR

MECHANICAL DRAWING		LEDiL [®]
PRODUCT -		
Plastic moulding general tolerances according to DIN 16901-130 and applies if not otherwise shown in the drawing. Silicone moulding general tolerances according to ISO 3302-1 Class M3 and applies if not otherwise shown in the drawing.	FIRST ANGLE PROJECTION: 	This drawing is the property of LEDiL Oy. It may not be copied or otherwise distributed without prior written permission from LEDiL Oy.
SCALE 1:1	WEIGHT 40,04 g	A3 SHEET 1/1

4

4

3

3

2

2

1

1

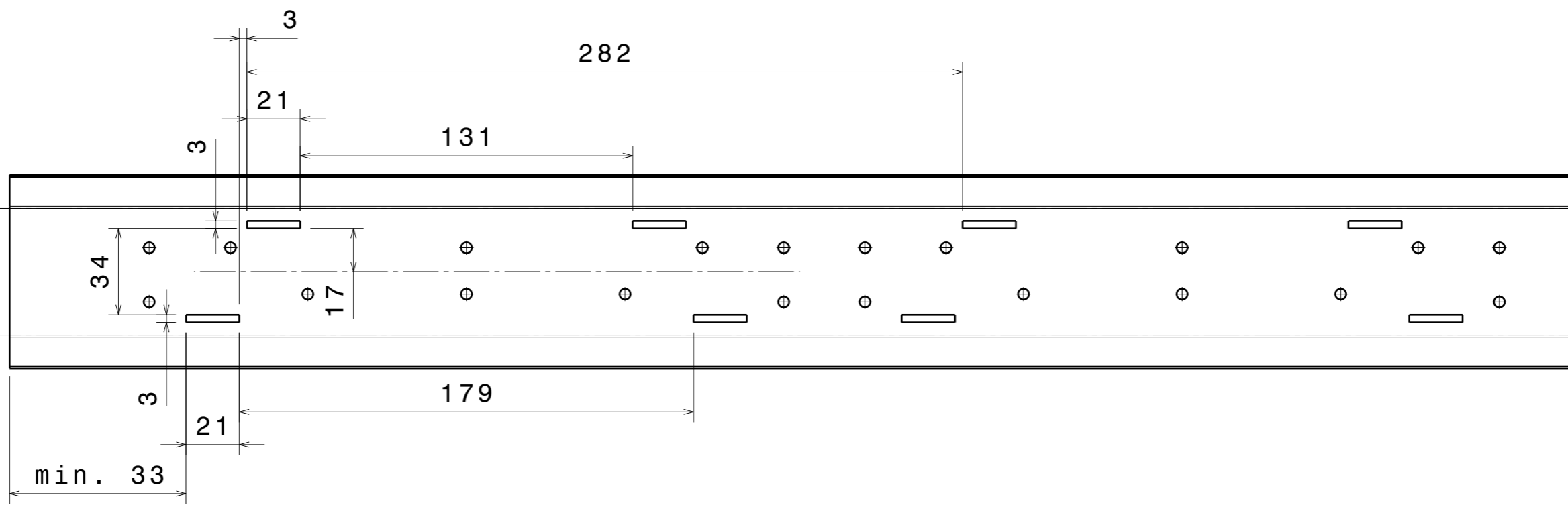

PART	TYPE	MATERIAL	COLOR / COATING
Linnea sheetmetal cut out			

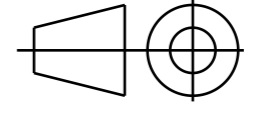
MECHANICAL DRAWING		LEDiL®
PRODUCT LINNEA		
Plastic moulding general tolerances according to DIN 16901-130 and applies if not otherwise shown in the drawing. Silicone moulding general tolerances according to ISO 3302-1 Class M3 and applies if not otherwise shown in the drawing.	FIRST ANGLE PROJECTION: 	This drawing is the property of LEDiL Oy. It may not be copied or otherwise distributed without prior written permission from LEDiL Oy.
SCALE 1:1	WEIGHT -	A3 SHEET 2/2