

DATE
02.07.2019

Dimension d	
RS	7.4
S	8.8
M	9.6
W	10.8
O	7.4
WAS	9.0

Note
Dimension d at bottom level,
value decrease inwards.

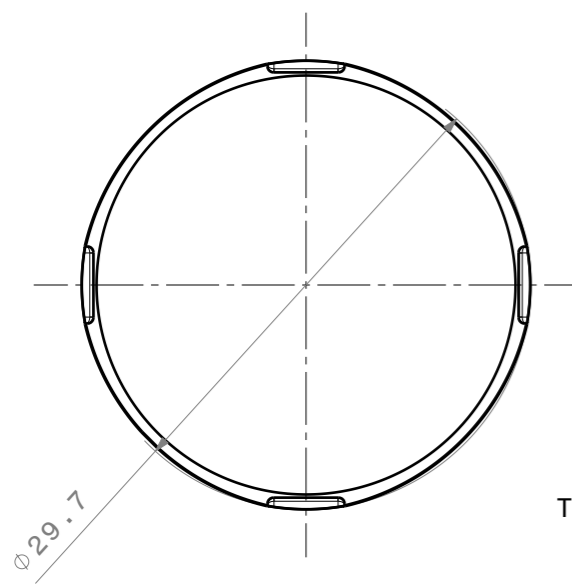

Top view

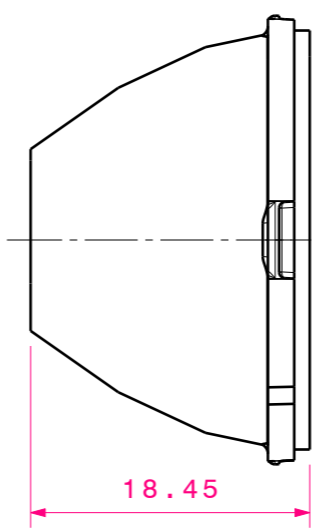

Front view

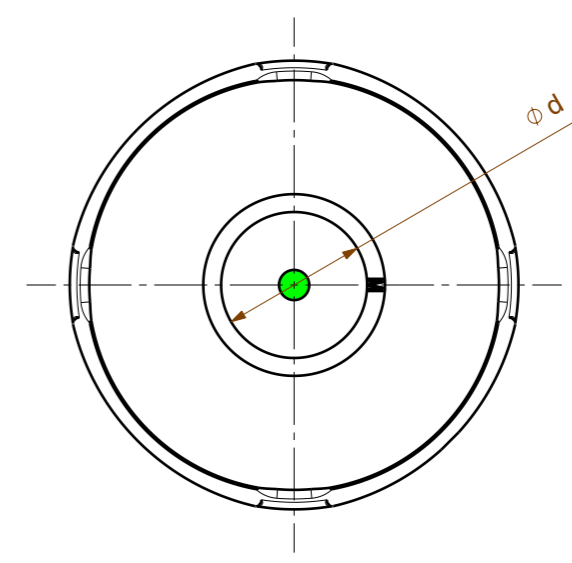

Bottom view

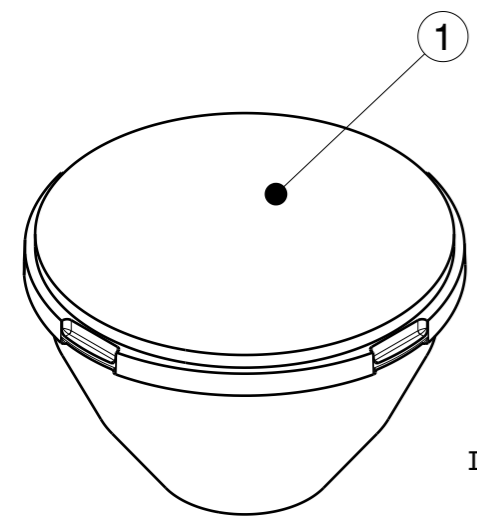

Isometric view

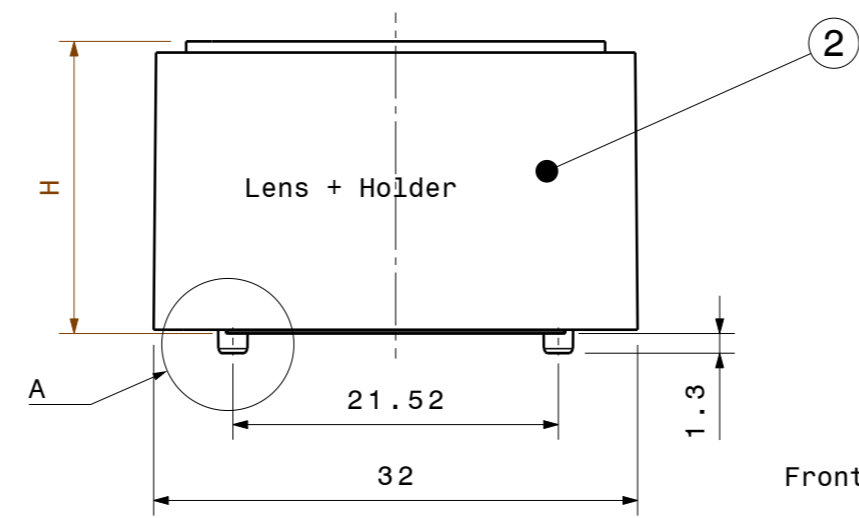

Front view

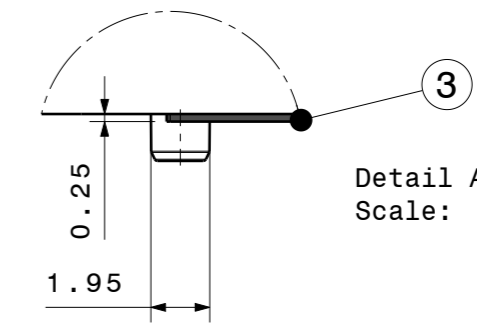

Detail A
Scale: 4:1

INDEX	PART	TYPE	MATERIAL	COLOR / COATING
1	C16123_OLGA-S	LENS	PMMA	CLEAR
1	C16124_OLGA-M	LENS	PMMA	CLEAR
1	C16125_OLGA-W	LENS	PMMA	CLEAR
1	C16307_OLGA-WAS	LENS	PMMA	CLEAR
1	C16671_OLGA-RS	LENS	PMMA	CLEAR
1	C16673_OLGA-O	LENS	PMMA	CLEAR
2	C16126_OLGA_HLD	HOLDER	PC	BLACK
3	C15177_SPUTNIK-TAPE3	TAPE	Acrylic foam	BLACK

This mechanical drawing can be used for following assembly codes		Dimension H
CA16127_OLGA-S		19.54
CA16128_OLGA-M		19.29
CA16129_OLGA-W		19.29
CA16308_OLGA-WAS		19.44
CA16672_OLGA-RS		19.46
C16673_OLGA-O		19.43

Notes
 LED location
 Ensure LED fitting from a product specific 3D model available from www.ledil.com
 For more details about installation please see LEDiL Installation Guide on www.ledil.com

MECHANICAL DRAWING		LEDiL®
PRODUCT OLGA FAMILY		
Plastic moulding general tolerances according to DIN 16901-130 and applies if not otherwise shown in the drawing. Silicone moulding general tolerances according to ISO 3302-1 Class M3 and applies if not otherwise shown in the drawing.	FIRST ANGLE PROJECTION: 	This drawing is the property of LEDiL Oy. It may not be copied or otherwise distributed without prior written permission from LEDiL Oy.
SCALE 2:1	WEIGHT -	A3 SHEET 1/1