

Bottom view
Scale: 1:2

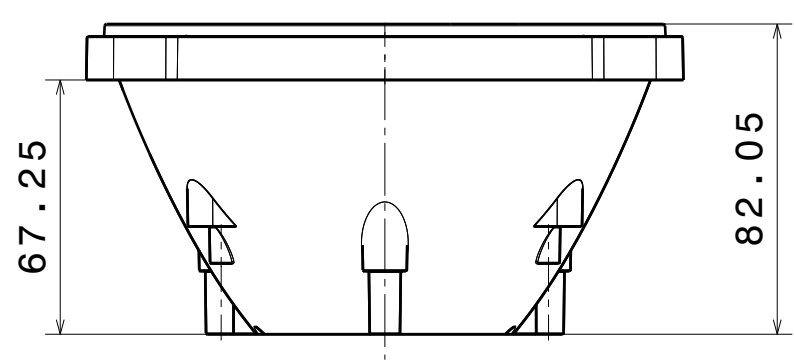

Front view

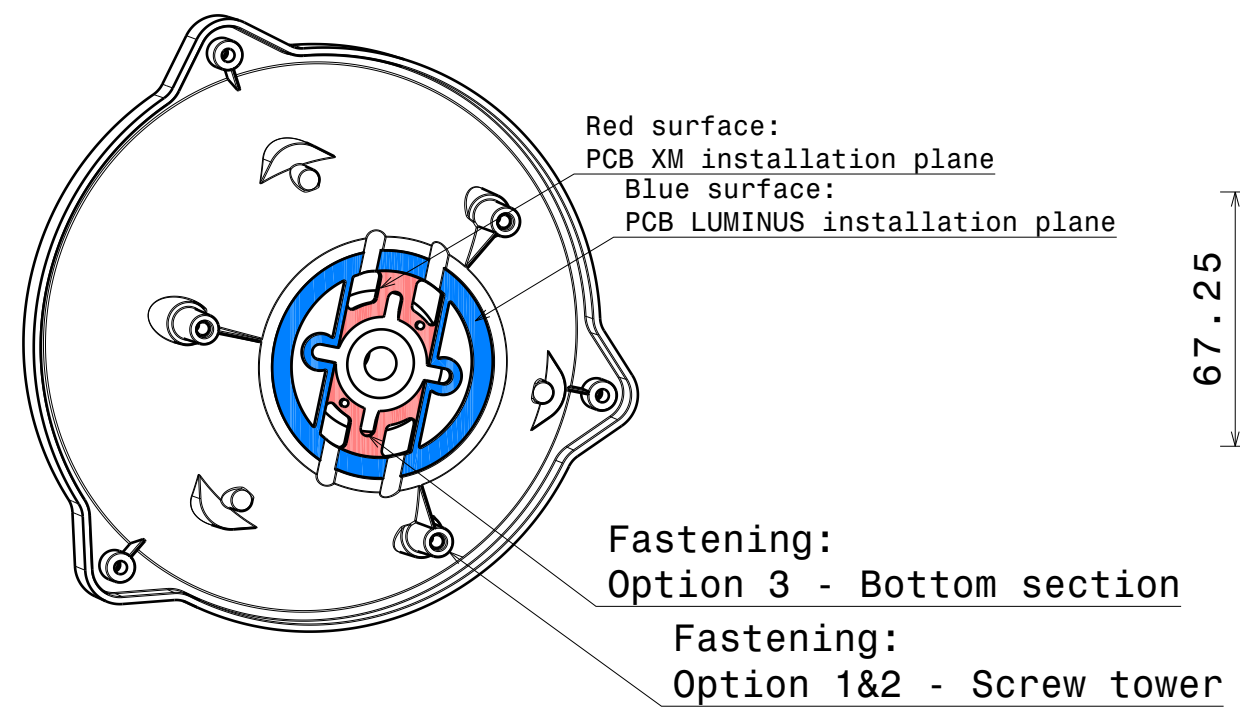
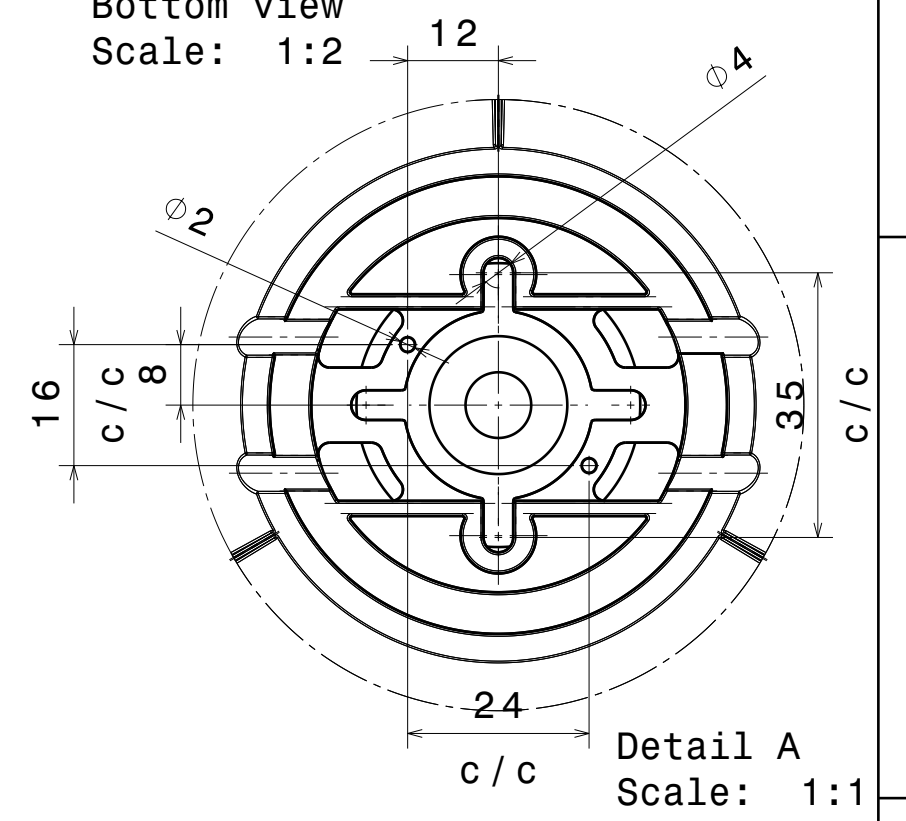

- Fastening:
- Option 1 - Fastening from top side through screw towers
 - Option 2 - Fastening from bottom side through heatsink and pcb to screw towers
 - Option 3 - Fastening from top side using bottom section screw holes

Tolerances if not otherwise shown According to DIN ISO 2768-1 Linear measures: Up to 30mm class M, otherwise class C. According to DIN ISO 2768-2 Form and position: class L		Ledil Oy Salorankatu 10 FIN 24240 SALO Finland	
THIRD ANGLE PROJECTION:		DRAWING TITLE FCN13895_SEANNA-A	
SIZE	PART NUMBER		
A3	Datasheet		
SCALE	1:2	WEIGHT	(g)
		SHEET	1/1