

**Notes**

- PCB or heat sink level
- Led location

Ensure LED fitting from a product specific 3D model available from [www.ledil.com](http://www.ledil.com)

See installation details page 2.

COMPONENTS				
INDEX	PRODUCT	TYPE	MATERIAL	COLOUR/COATING
1	F15811_STRADA-2X2MXS-VSM	LENS	Silicone	CLEAR
2	F14813_STRADA-2X2MXS-FRAME	Frame	PA66GF30	Black

MECHANICAL DRAWING			<b>LEDiL</b> <sup>®</sup>	
PRODUCT				
FP15812_STRADA-2X2MXS-VSM				
Plastic moulding general tolerances according to DIN 16901-130 and applies if not otherwise shown in the drawing. Silicone moulding general tolerances according to ISO 3302-1 Class M3 and applies if not otherwise shown in the drawing.	FIRST ANGLE PROJECTION:		This drawing is the property of LEDiL Oy. It may not be reproduced, copied or communicated without a written agreement with LEDiL Oy.	
SCALE	2:3	SIZE	A3	SHEET 1/2

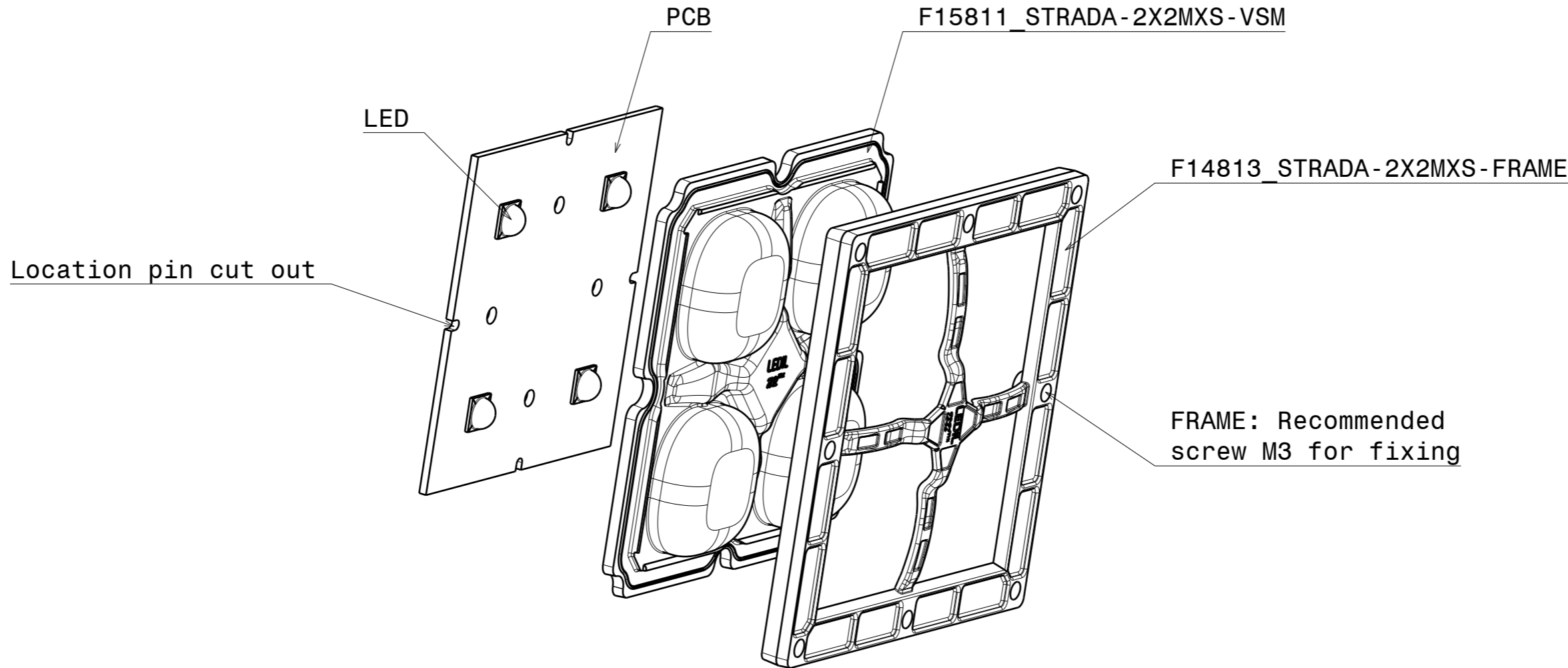

**Notes**

For more details about installation please see LEDiL Installation Guide on [www.ledil.com](http://www.ledil.com)

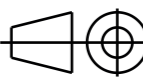
<b>MECHANICAL DRAWING</b>		<b>LEDiL<sup>®</sup></b>
PRODUCT FP15812_STRADA-2X2MXS-VSM		
Plastic moulding general tolerances according to DIN 16901-130 and applies if not otherwise shown in the drawing. Silicone moulding general tolerances according to ISO 3302-1 Class M3 and applies if not otherwise shown in the drawing.	FIRST ANGLE PROJECTION: 	This drawing is the property of LEDiL Oy. It may not be reproduced, copied or communicated without a written agreement with LEDiL Oy.
SCALE 2:1	SIZE A3	SHEET 2/2