

Recommended screw M3 for fixing
Use washer with screw if possible

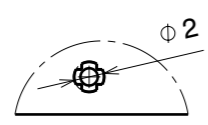
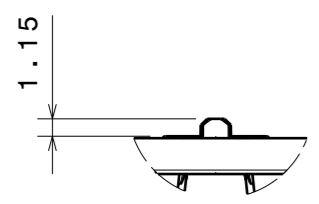
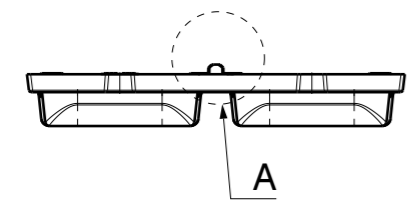
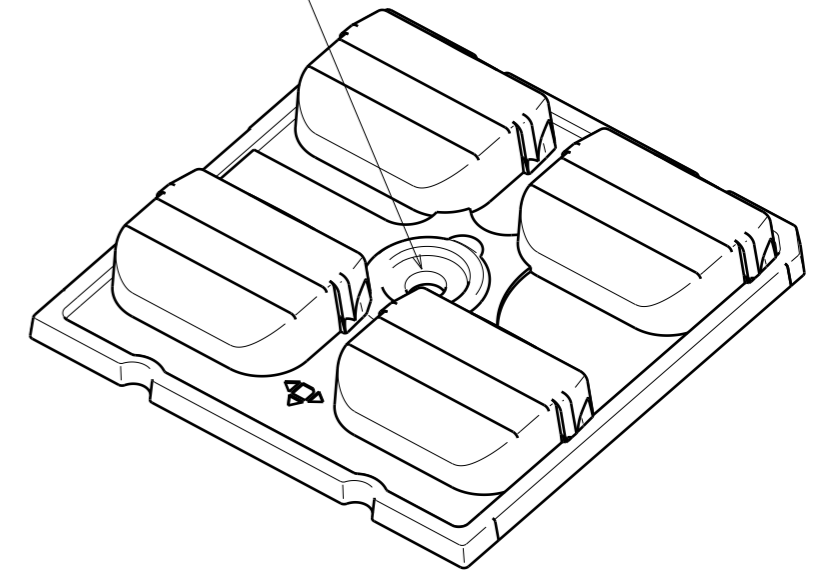

Detail A
Scale: 2:1

Detail B
Scale: 2:1

Position pin 2pcs
Cut out needed to PCB

Recess 4pcs for LED

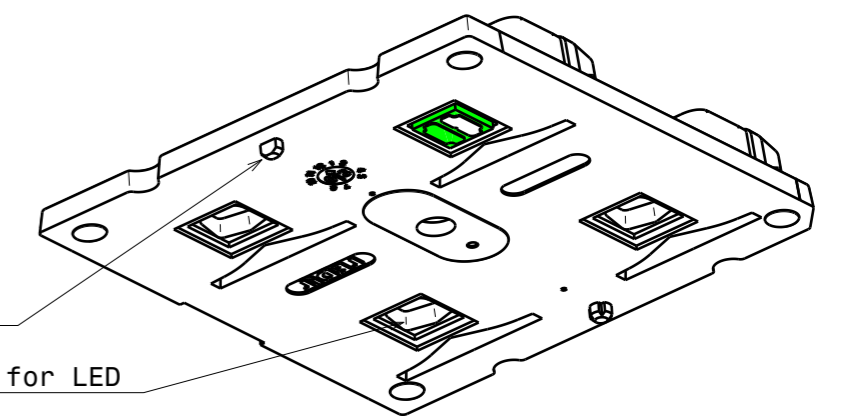

Notes

	PCB or heatsink level.
	LED location
	Ensure LED fitting from a product specific 3D model available from www.ledil.com
	For more details about installation please see LEDiL Installation Guide on www.ledil.com

PART	TYPE	MATERIAL	COLOR / COATING
C16637_STRADA-2X2-5050-T2-C	LENS	PMMA	CLEAR

MECHANICAL DRAWING
PRODUCT STRADA



Plastic moulding general tolerances according to DIN 16901-130 and applies if not otherwise shown in the drawing. Silicone moulding general tolerances according to ISO 3302-1 Class M3 and applies if not otherwise shown in the drawing.

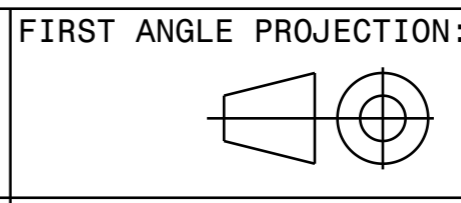

This drawing is the property of LEDiL Oy. It may not be copied or otherwise distributed without prior written permission from LEDiL Oy.

SCALE	1:1	WEIGHT	10.0g	A3	SHEET 1/1
-------	-----	--------	-------	----	-----------