

isometric view
Note: Mechanical model shown

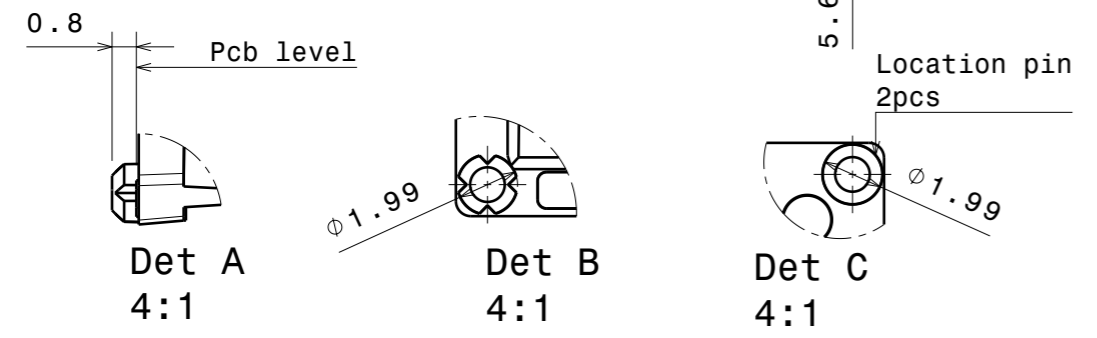

PART	TYPE	MATERIAL	COLOR / COATING
C18437_STRADELLA-8-HV-ME3	Lens	PMMA	Clear

MECHANICAL DRAWING	
PRODUCT	Stradella
Plastic moulding general tolerances according to DIN 16901-130 and applies if not otherwise shown in the drawing. Silicone moulding general tolerances according to ISO 3302-1 Class M3 and applies if not otherwise shown in the drawing.	FIRST ANGLE PROJECTION:
SCALE 2:1	WEIGHT 7.2g

LEDiL	
This drawing is the property of LEDiL Oy. It may not be copied or otherwise distributed without prior written permission from LEDiL Oy.	
A3	SHEET 1/1

- Notes**
- PCB or heatsink level.
 - LED location
 - Maximum tightening torque for the center screw is 0.6 Nm
 - Recommended lens attachment screws are of type pan head, M3.
 - Ensure LED fitting from a product specific 3D model available from www.ledil.com
 - For more details about installation please see LEDiL Installation Guide on www.ledil.com