

Auxiliary view C
Scale: 1:1

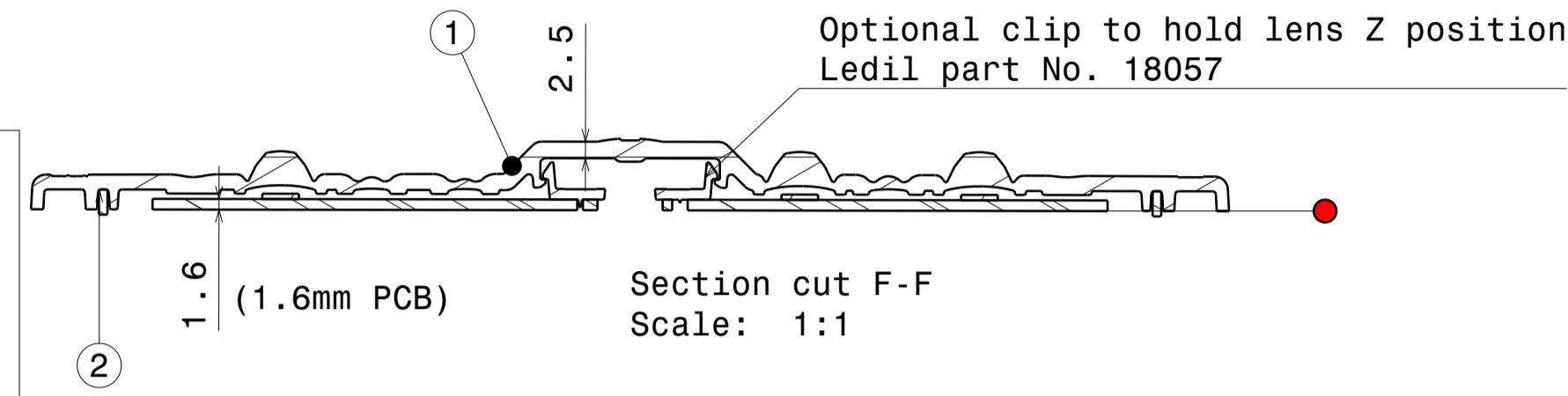

Section cut F-F
Scale: 1:1

Silicone seal is tested to work in LEDiL test assemblies. Customer is recommended to test the sealing in the end product due many variables, such as heat sink surface and possible chemical traces

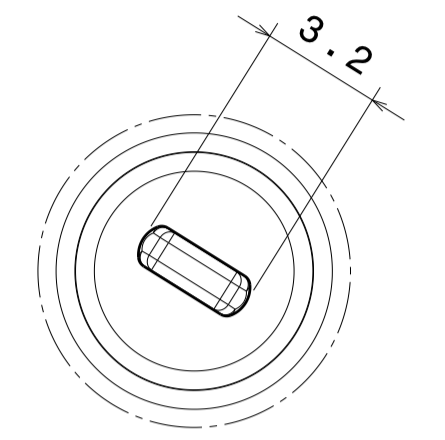

Detail E
Scale: 5:1

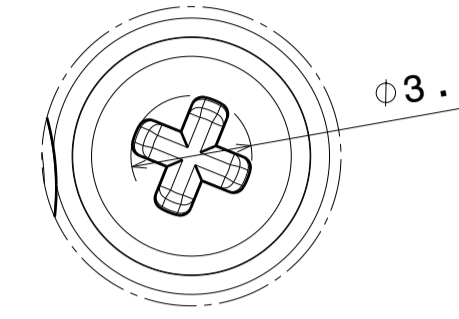

Detail D
Scale: 5:1

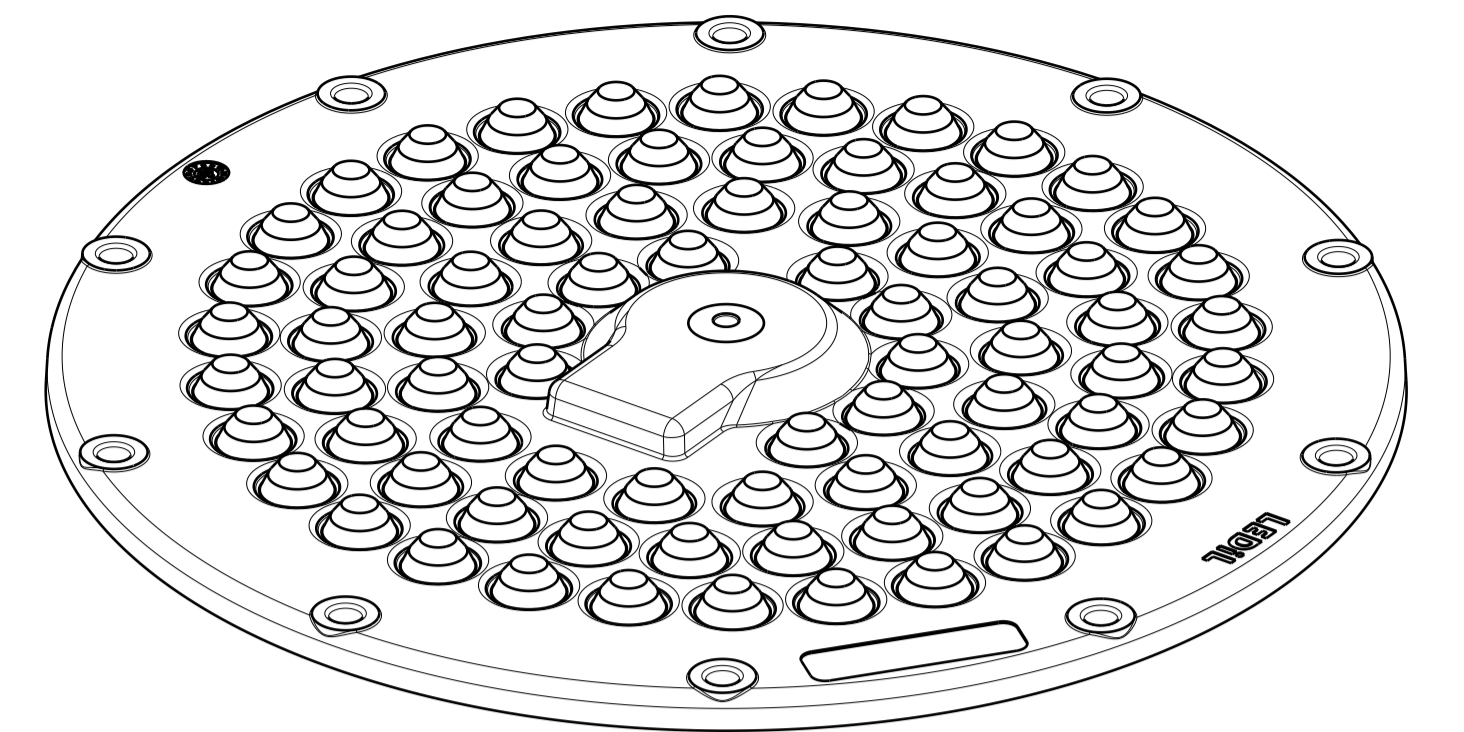

Isometric View
Scale: 1:1

Recommended torque with pan head screw: 0,6Nm

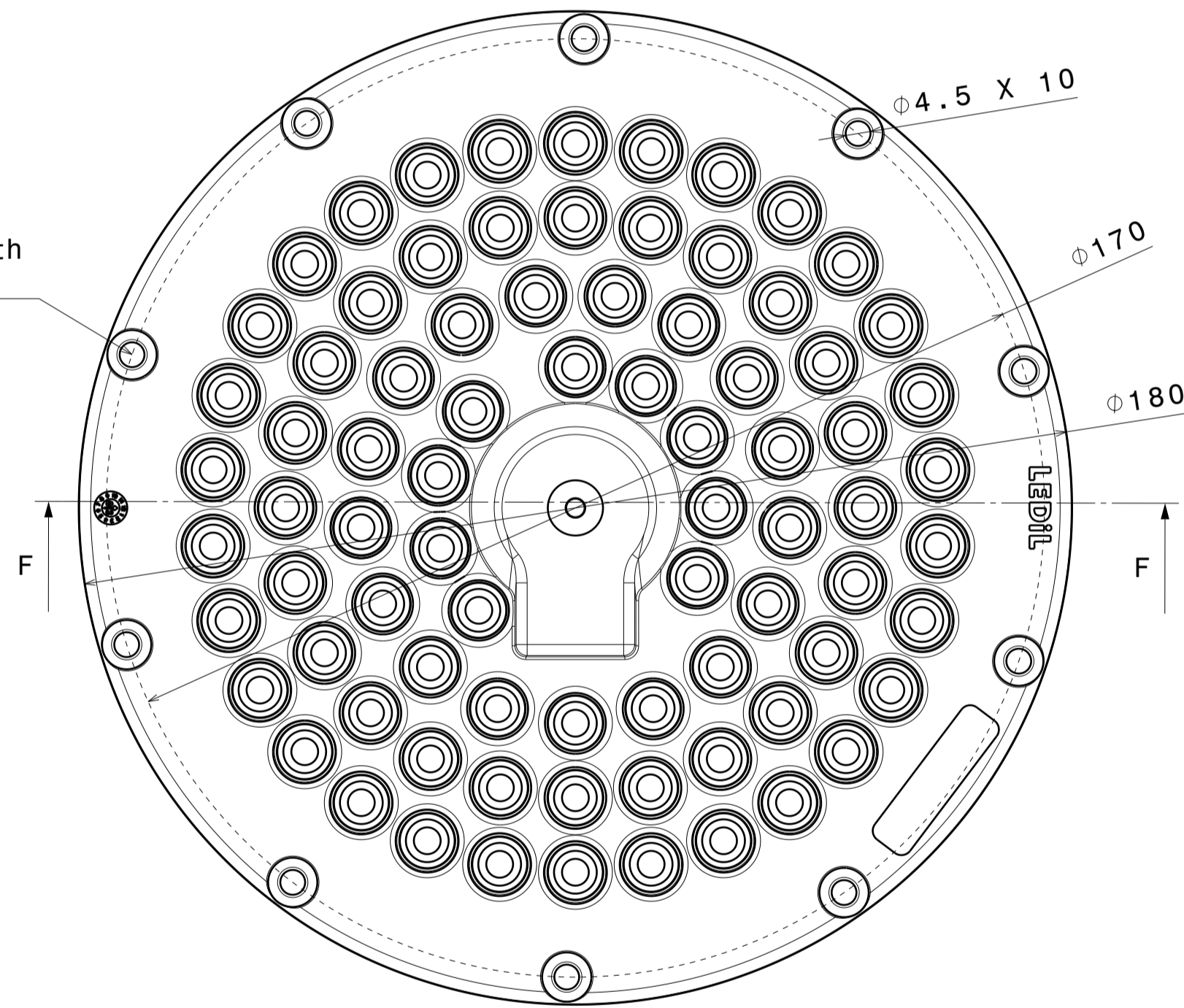

Top View
Scale: 1:1

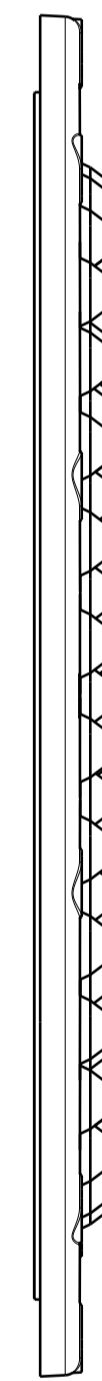

Auxiliary view A
Scale: 1:1

Wiring:
PCB is fully sealed between the lens with silicone seal and the heatsink. Wiring needs to be done through the PCB and heatsink to maintain IP rating

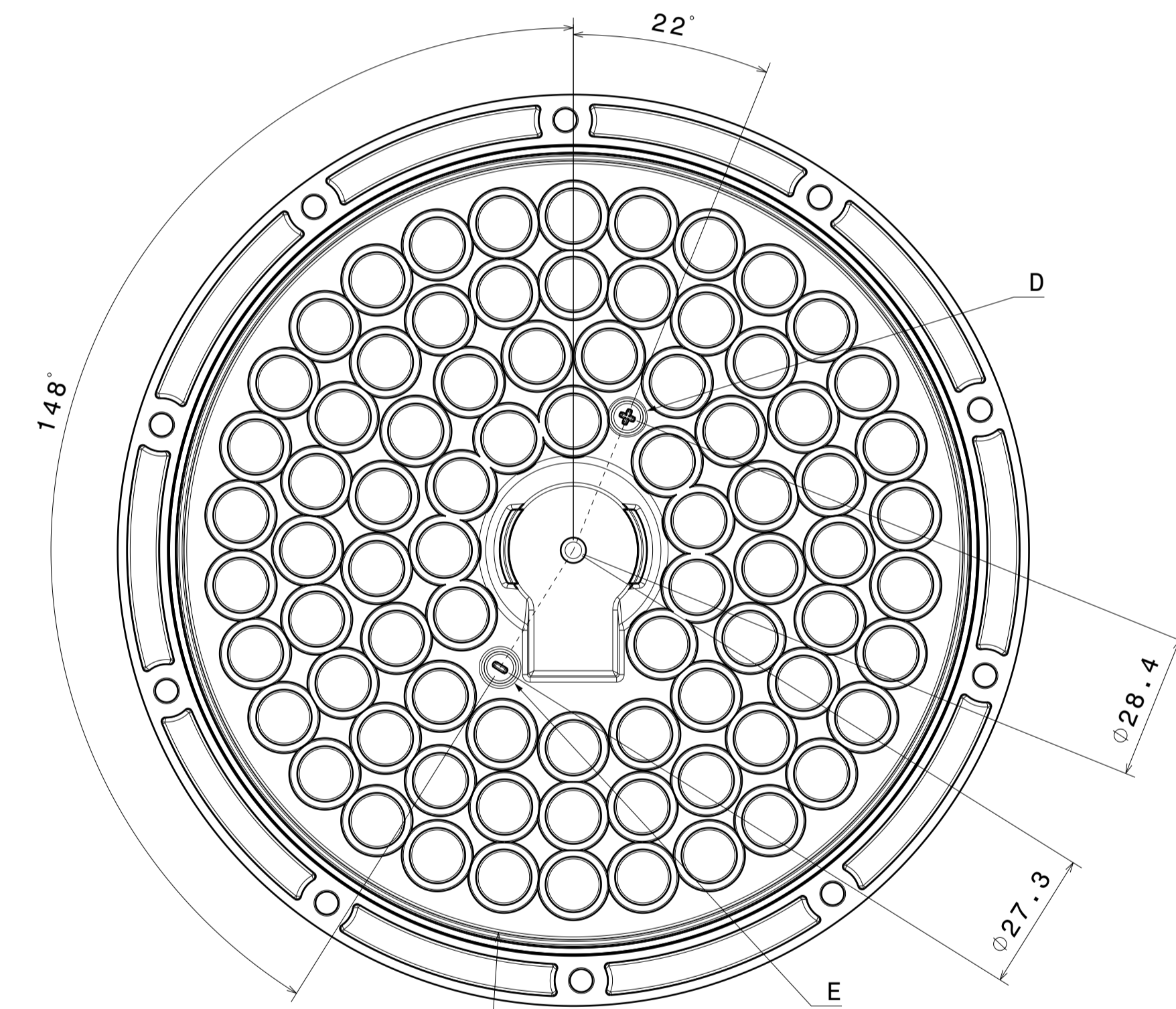

Auxiliary view B
Scale: 1:1

CS17977_VICTORIA-MINI-W-PC
COMPONENTS

INDEX	PART	TYPE	MATERIAL	COLOR / COATING
2	C17976_VICTORIA-MINI-SEAL		Silicone	
1	C18054_VICTORIA-MINI-W-PC		PC	Clear

MECHANICAL DRAWING		LEDiL®
PRODUCT	VICTORIA-MINI	
Plastic moulding general tolerances according to DIN 16901-130 and applies if not otherwise shown in the drawing. Silicone moulding general tolerances according to ISO 3302-1 Class M3 and applies if not otherwise shown in the drawing.	FIRST ANGLE PROJECTION: 	This drawing is the property of LEDiL Oy. It may not be copied or otherwise distributed without prior written permission from LEDiL Oy.
SCALE	1:1	WEIGHT 97,4g
		A1 SHEET 1/1

Notes
 PCB or heatsink level.
 LED location
 Ensure LED fitting from a product specific 3D model available from www.ledil.com
 For more details about installation please see LEDiL Installation Guide on www.ledil.com

1. Install PCB with M3 countersunk screws

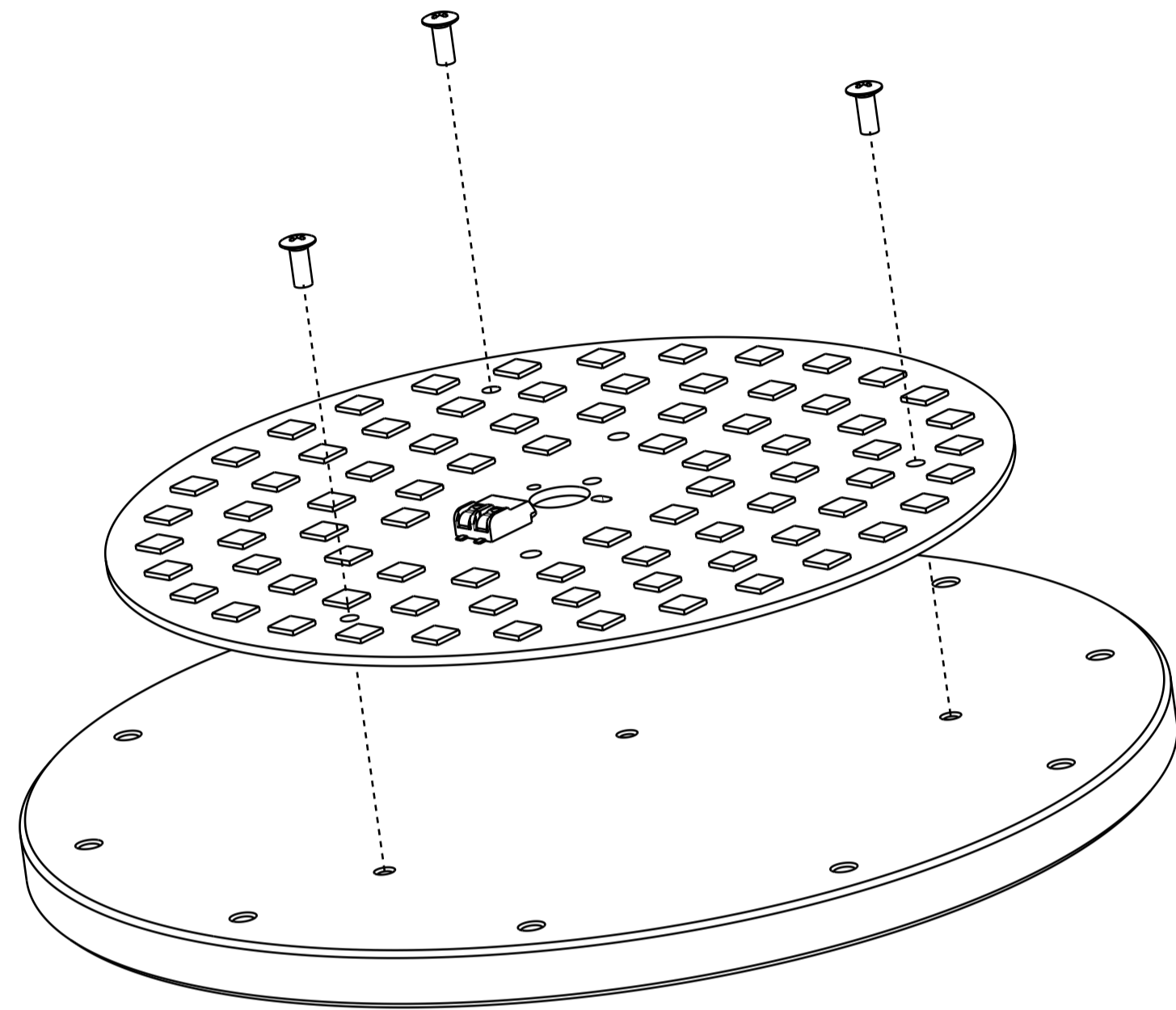

2. Install Clip with M3 screw

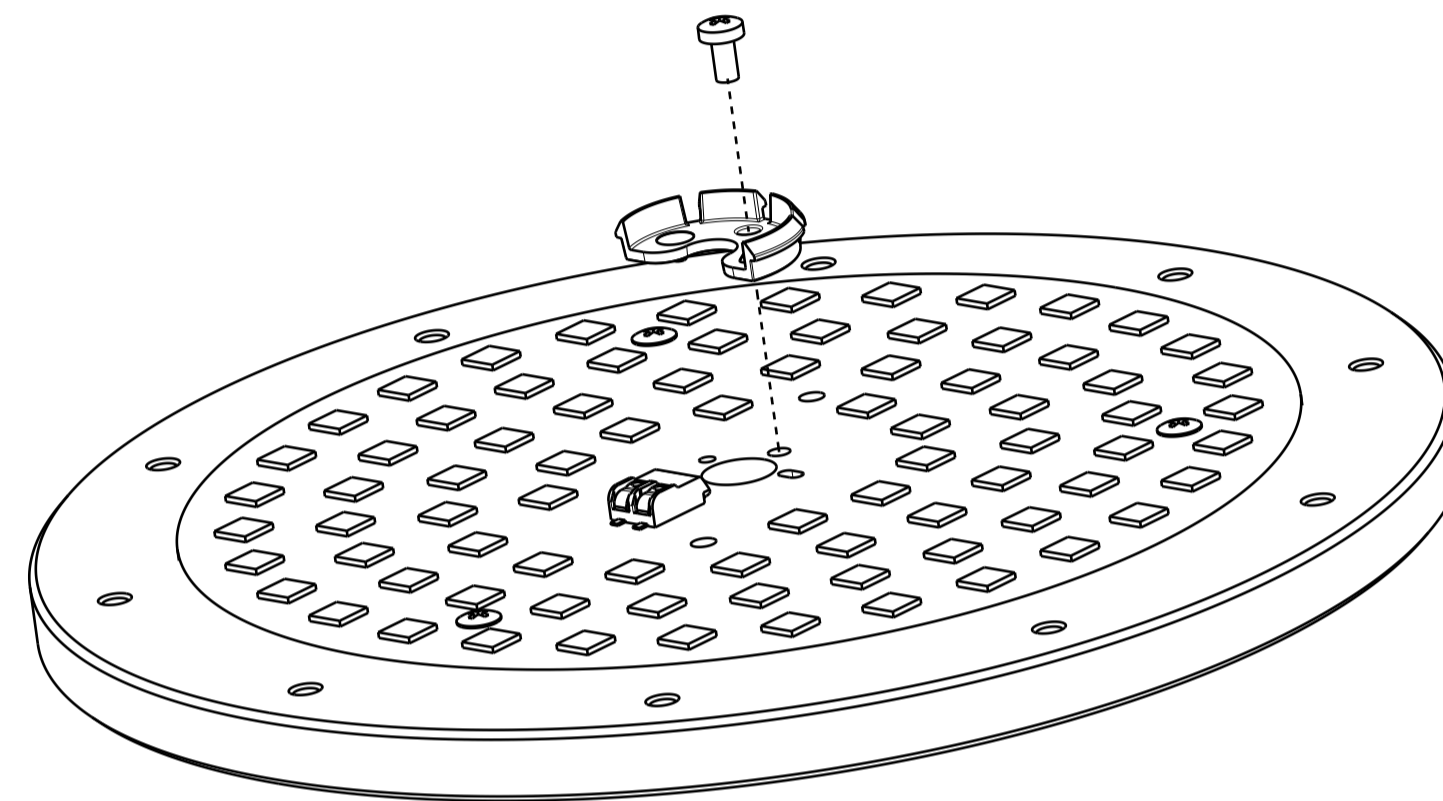

3. Push lens down to clip and rotate position pins to match corresponding holes in PCB

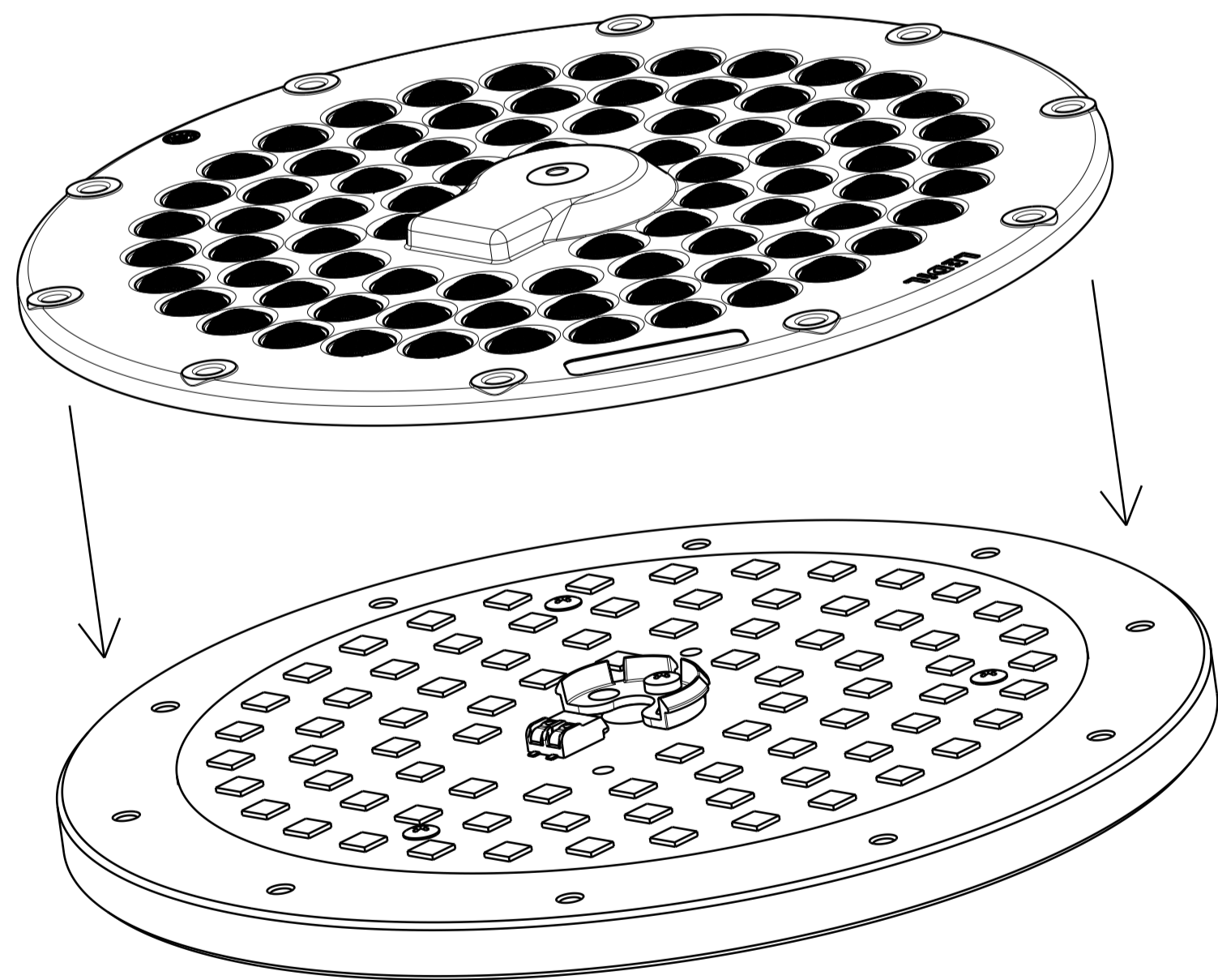

4. Fix the lens with M4 screws

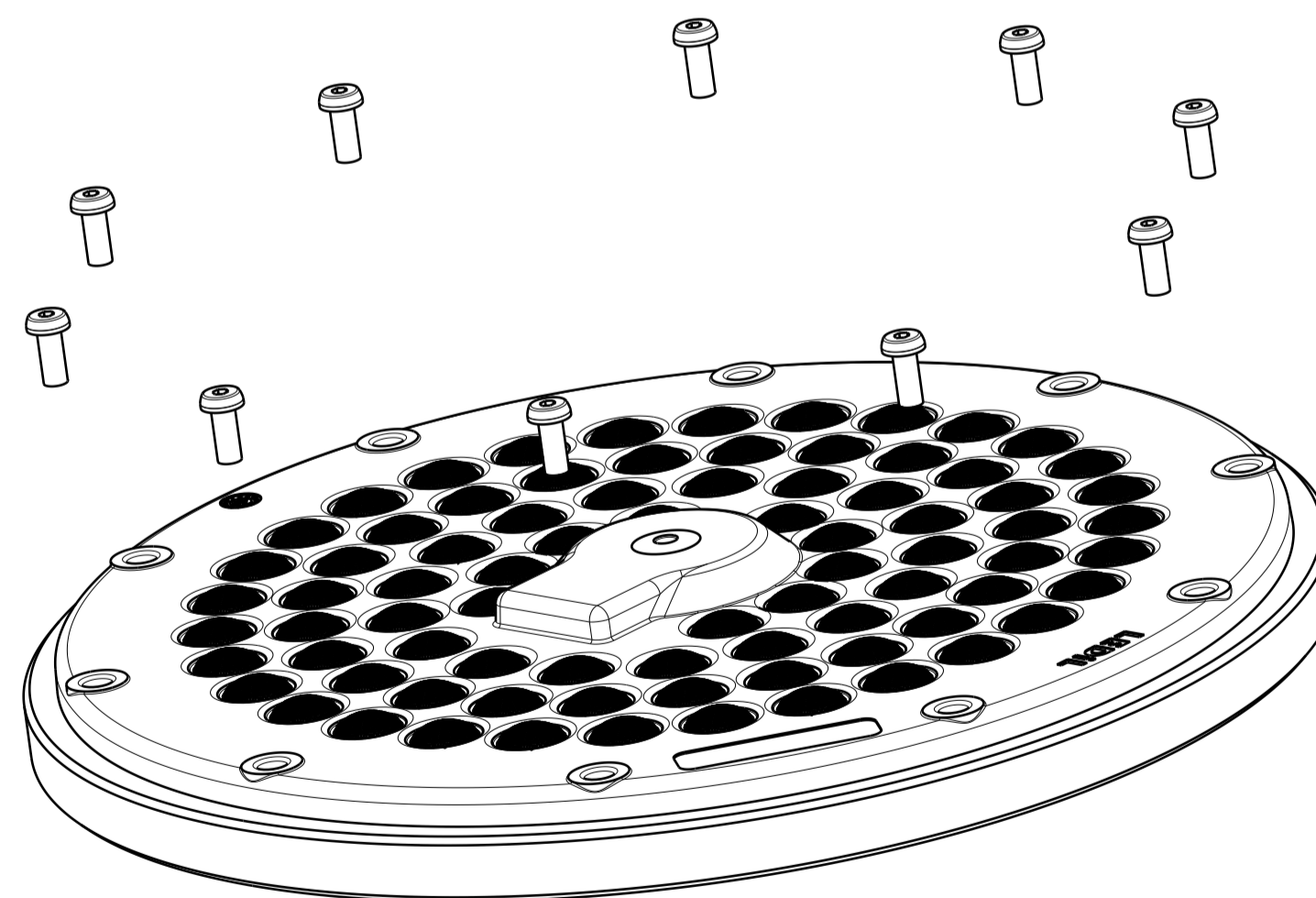

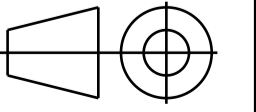
MECHANICAL DRAWING		LEDiL [®]
PRODUCT	VICTORIA-MINI	
<small>Plastic moulding general tolerances according to DIN 16901-130 and applies if not otherwise shown in the drawing. Silicone moulding general tolerances according to ISO 3302-1 Class M3 and applies if not otherwise shown in the drawing.</small>	FIRST ANGLE PROJECTION: 	<small>This drawing is the property of LEDiL Oy. It may not be copied or otherwise distributed without prior written permission from LEDiL Oy.</small>
SCALE	1:1	A1 SHEET 1/1
	WEIGHT	-