

Isometric view

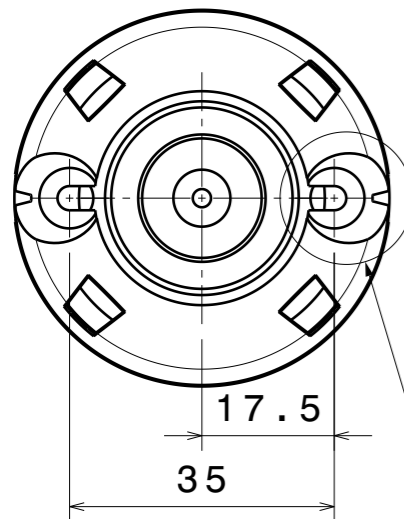

Bottom view

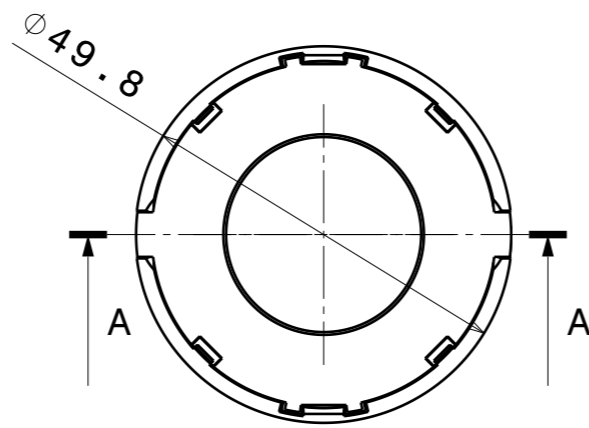

Top view

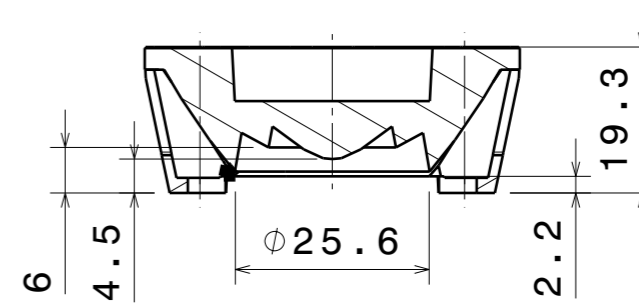

Section view A-A

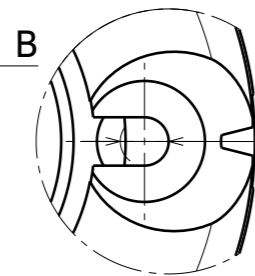

$\phi 3.2$
fastening with M3
pan head screws

Notes

3D model is always the master. For complete documentation,
drawing must be accompanied with related 3D model file name.format/date.
Ejector location to be agreed with Ledil Oy.

| INDEX | PART | TYPE | MATERIAL | COLOR / COATING |
|-------|----------------------|--------|----------|-----------------|
| 1 | C14232_WINNIE-S | LENS | PMMA | CLEAR |
| 2 | C14235_WINNIE-HOLDER | HOLDER | PC | WHITE |

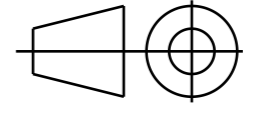
| | | |
|---|--|---|
| MECHANICAL DRAWING | | LEDiL® |
| PRODUCT | WINNIE | |
| Plastic moulding general tolerances according to DIN 16901-130 and applies if not otherwise shown in the drawing. Silicone moulding general tolerances according to ISO 3302-1 Class M3 and applies if not otherwise shown in the drawing. | FIRST ANGLE PROJECTION:  | This drawing is the property of LEDiL Oy. It may not be copied or otherwise distributed without prior written permission from LEDiL Oy. |
| SCALE | 1:1 | WEIGHT - |
| | | A3 SHEET 1/1 |